

# INSTRUCTION MANUAL

Serial Number \_\_\_\_\_

TYPE **M**  
PLUG-IN UNIT

*Tektronix, Inc.*

S.W. Millikan Way • P. O. Box 500 • Beaverton, Oregon • Phone MI 4-0161 • Cables: Tektronix  
070-295

1263



## WARRANTY

All Tektronix instruments are warranted against defective materials and workmanship for one year. Tektronix transformers, manufactured in our own plant, are warranted for the life of the instrument.

Any questions with respect to the warranty mentioned above should be taken up with your Tektronix Field Engineer.

Tektronix repair and replacement-part service is geared directly to the field, therefore all requests for repairs and replacement parts should be directed to the Tektronix Field Office or Representative in your area. This procedure will assure you the fastest possible service. Please include the instrument Type and Serial number with all requests for parts or service.

Specifications and price change privileges reserved.

Copyright © 1963 by Tektronix, Inc., Beaverton, Oregon. Printed in the United States of America. All rights reserved. Contents of this publication may not be reproduced in any form without permission of the copyright owner.



## CONTENTS

Warranty

- Section 1 Characteristics
- Section 2 Operating Instructions
- Section 3 Circuit Description
- Section 4 Maintenance
- Section 5 Calibration
- Section 6 Parts List and Diagrams

A list of abbreviations and symbols used in this manual will be found on page 6-1. Change information, if any, is located at the rear of the manual.

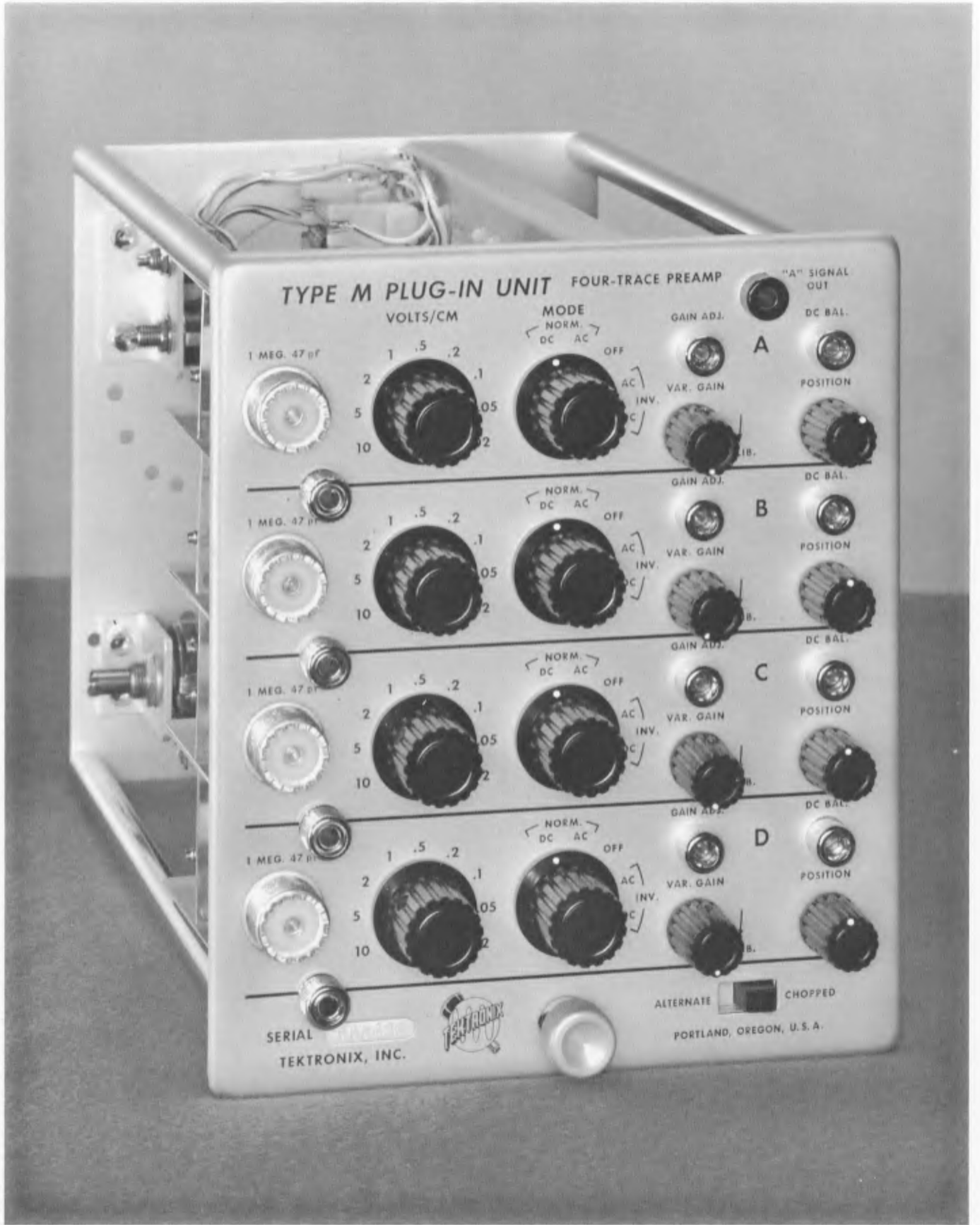

TYPE M PLUG-IN UNIT FOUR-TRACE PREAMP

VOLTS/CM

1 MEG. 47 pF

1  
2  
5  
10

1 .5 .2  
.1  
.05  
.2

MODE  
NORM.  
DC AC OFF

AC INV. C

GAIN ADJ.

VAR. GAIN

IB.

"A" SIGNAL OUT

A

DC BAL.

POSITION

1 MEG. 47 pF

1  
2  
5  
10

1 .5 .2  
.1  
.05  
.2

NORM.  
DC AC OFF

AC INV. C

GAIN ADJ.

VAR. GAIN

IB.

B

DC BAL.

POSITION

1 MEG. 47 pF

1  
2  
5  
10

1 .5 .2  
.1  
.05  
.2

NORM.  
DC AC OFF

AC INV. C

GAIN ADJ.

VAR. GAIN

IB.

C

DC BAL.

POSITION

1 MEG. 47 pF

1  
2  
5  
10

1 .5 .2  
.1  
.05  
.2

NORM.  
DC AC OFF

AC INV. C

GAIN ADJ.

VAR. GAIN

IB.

D

DC BAL.

POSITION

SERIAL    
TEKTRONIX, INC.



ALTERNATE  CHOPPED

PORTLAND, OREGON, U.S.A.

Type M

# SECTION 1

## CHARACTERISTICS

### General Information

The Type M Plug-In Unit preamplifier contains four identical channels that can be used separately or electronically switched to produce single- or multi-trace displays. The unit thus provides a convenient means for viewing one to four signals, either separately or in combination, reducing cable switching to a minimum. Each amplifier in the unit has its own attenuator, mode, gain, and position control, which enables the display to be adjusted for optimum viewing and information.

When using the channels separately (without electronic switching), the M Unit is useful in all single-trace applications within its frequency and sensitivity capabilities.

During the alternate mode of operation, when the oscilloscope sweep is set for free-running operation, the sweep triggers the M Unit and one to four traces can be displayed alternately. The number of traces depends upon the setting of the MODE switches. In applications where signals, related in repetition rate to the sweep, are applied to the M Unit input connectors, a stable display can be obtained.

In the alternate mode of operation, when the oscilloscope is set for triggered operation, stationary displays of four signals unrelated in frequency can be obtained. The signals internally trigger the sweep which, in turn, triggers the M Unit to produce alternate displays. Because the sweeps are identical and time-delay characteristics of the

four channels are equal, accurate time comparisons can be made between signals.

In the chopped mode of operation, channel switching occurs at a rate of approximately 1 mc divided by the number of channels in use, making it possible to view from one to four simultaneous transients. The number of displayed waveforms depends on the setting of the MODE switches and the number of inputs used. In four-trace operation transients of as little as 0.5 millisecond duration can be well delineated, with approximately 125 elements in each trace. For many purposes, shorter transients can be adequately observed.

### Amplifier Sensitivity

Nine calibrated steps are provided for each channel: 0.02, 0.05, 0.1, 0.2, 0.5, 1, 2, 5 and 10 volts/cm. Accuracy is within 3% of panel reading. Variable controls for each channel permit continuous adjustment (uncalibrated) from 0.02 to 25 volts/cm.

### Amplifier Transient Response and Bandwidth

Your instrument was adjusted at the factory for optimum transient response. Table 1-1 summarizes the risetime and approximate bandwidths available when the M Unit is used in combination with various oscilloscopes.

**TABLE 1-1  
TRANSIENT RESPONSE AND BANDWIDTH**

Oscilloscope - M Unit Combination	Risetime	Bandwidth (at -3 db points)	
	MODE switch in any position except OFF	MODE switch in either DC position	Mode switch in either AC position
541, 541A, 543, 543A, 545, 545A, 555, 581*, 585*, 581A*, 585A* or RM585A*	17 nsec	dc to 20 mc	2 cps to 20 mc; 0.2 cps to 20 mc with P6006 Probe or equivalent
551	18 nsec	dc to 19 mc	2 cps to 19 mc; 0.2 cps to 19 mc with P6006 Probe or equivalent
531, 531A, 533, 533A, 535 or 535A	25 nsec	dc to 14 mc	2 cps to 14 mc; 0.2 cps to 14 mc with P6006 Probe or equivalent
536	35 nsec	dc to 10 mc	2 cps to 10 mc; 0.2 cps to 10 mc with P6006 Probe or equivalent
532	70 nsec	dc to 5 mc	2 cps to 5 mc; 0.2 cps to 5 mc with P6006 Probe or equivalent

Type 81 or Type 81A Plug-In Adapter required for use with the Type 580A Series Oscilloscopes.

## Characteristics—Type M

### Operating Modes

Channels A, B, C, or D, separately.

Chopped—Sequential electronic switching of channels at approximately 1-mc rate.

Alternate—Triggered electronic switching of channels at the end of each sweep, during retrace intervals.

Front-panel switches, in conjunction with the chopped or alternate modes of operation, permit viewing any combination up to four channels.

### Polarity Inversion

Polarity of any channel selected can be inverted for comparison of signals 180° out of phase.

### Input Coupling

Choice of ac or dc coupling. In the AC positions of the MODE switch a coupling capacitor is inserted, limiting the low-frequency response to approximately 2 cycles at 3 db down.

### Input Characteristics (Approximate)

1 megohm  $\pm 1\%$  paralleled by approximately 47 pf.

### Maximum Allowable Combined DC and Peak AC Input

600 volts.

### Construction

Aluminum-alloy chassis.

### Finish

Anodized aluminum front panel.

### Accessories

Information on accessories for use with this instrument is included at the rear of the mechanical parts list.

# SECTION 2

## OPERATING INSTRUCTIONS

### FRONT-PANEL CONTROLS AND CONNECTORS

Functions of the channel A front-panel controls, channel A connectors, ALTERNATE/CHOPPED switch and Securing Rod are described in Table 2-1. The functions of the front-panel controls and input connectors for the other channels are the same as for channel A. Grouping of the front-panel controls and connectors is shown in Fig. 2-1.

**TABLE 2-1**

Input Connector .....	Connector for coupling ac or dc signals to the channel A amplifier.
VOLTS/CM .....	Nine-position switch to select the calibrated vertical-deflection factors.
MODE .....	Five-position switch to provide a choice of ac or dc coupling, operational in-phase (normal) or out-of-phase (inverted) output, or to turn the channel "off".

GAIN ADJ ..... Screwdriver-adjust potentiometer to set the gain of the amplifier accurately.

VAR. GAIN ..... Potentiometer to provide continuously variable attenuation between the calibrated sensitivities and to extend the attenuation to a sensitivity of 25 volts/cm. This control does not have a mechanical stop and is therefore continuously variable. It does, however, have a detent stop for the CALIB. (calibrated) position.

"A" SIGNAL OUT ..... Output signal from channel A. Amplitude is 2 volts for each cm of display on crt. Bandwidth of the internal channel A Signal Output Amplifier is about 1.0 mc —3 db (750 kc with gradual roll-off, SN 101-2759).

DC BAL ..... Screwdriver-adjust potentiometer to set the dc level so the trace does not shift position as the VAR. GAIN control is adjusted.

POSITION ..... Potentiometer to shift the trace position vertically.

ALTERNATE/CHOPPED .. Slide switch to select either alternate or chopped mode of operation. When used in conjunction with the MODE switches, the ALTERNATE/CHOPPED switch permits viewing any combination of channels in either mode of operation.

Securing Rod ..... Holds the M Unit securely in the oscilloscope plug-in compartment. (The Securing Rod is located at bottom center on the front panel.)

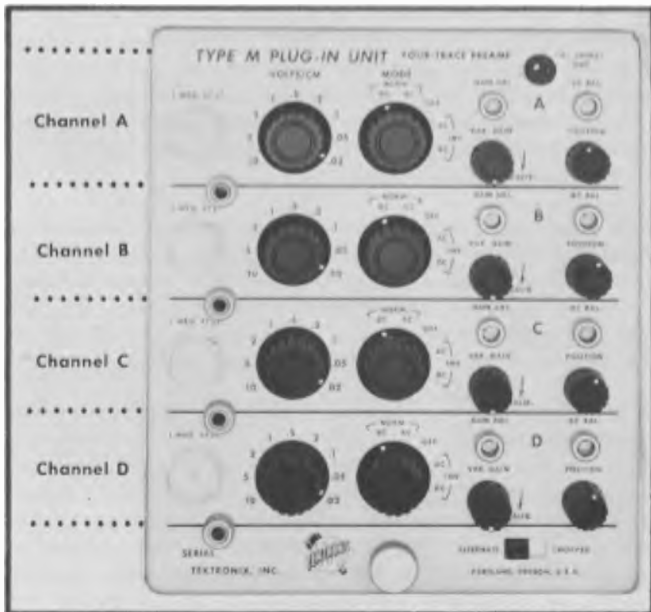

Fig. 2-1. Front-panel view of the Type M Plug-In Unit showing the grouping of the controls and connectors for each channel.

### FIRST TIME OPERATION

Plug the M Unit into a Type 530-, 540-, 550-, or 580-Series\* Tektronix oscilloscope, tighten the Securing Rod, and turn the power on. Allow the instrument to reach operating temperature, about 2 to 3 minutes, and free-run the oscilloscope sweep at 0.5 millisec/cm. Set the front-panel controls of the M Unit as follows:

\* A Type 81 Adapter required for use with 580 and 580A Series Oscilloscopes.

## Operating Instructions—Type M

VOLTS/CM (All channels)	.02
MODE (channel A)	DC NORM.
MODE (channels B, C and D)	OFF
VAR. GAIN (all channels)	CALIB.
POSITION (all channels)	Centered
ALTERNATE/CHOPPED	ALTERNATE

1. Position the trace to about +2 cm with the channel A POSITION control.
2. Set the channel B MODE switch to the DC NORM. position and position the B trace to about +1 cm with the channel B POSITION control.
3. Set the channel C MODE switch to DC NORM. and position the C trace to about -1 cm with the channel C POSITION control.
4. Set the channel D MODE switch to DC NORM. and position the D trace to about -2 cm with the channel D POSITION control. This makes a total of four traces which appear on the crt screen. For each sweep cycle one channel is conducting and the others are cut off. The channels are switched alternately at the end of each sweep cycle, during retrace intervals.
5. To observe the alternate trace switching cycle at a slower rate, decrease the sweep rate to 0.1 sec/cm.
6. To observe the CHOPPED mode of operation set the ALTERNATE/CHOPPED switch to the CHOPPED position.
7. Set the oscilloscope triggering controls for  $\pm$ Internal triggered-sweep operation. Notice that all four traces seem to start simultaneously and continue on across the screen.
8. Increase the sweep rate to 10  $\mu$ sec/cm. Adjust the oscilloscope Triggering Level control to obtain a stable display. Notice that each trace is composed of several short-duration elements with switching-transient traces existing between the channels. [To blank out the switching transients, set the CRT Cathode Selector switch (located at the rear of most Tektronix oscilloscopes) to the Dual-Trace Chopped Blanking position.]

All four channels are being switched successively at a rate of approximately 1 mc. Increase the sweep rate to 1  $\mu$ sec/cm. Observe that each channel conducts for about 1  $\mu$ sec and then is cut off for 3  $\mu$ sec while the three other channels each conduct for 1  $\mu$ sec. Chopping rate of each channel is 250 kc (1 mc divided by the number of channels in use). Approximate switching time between channels is 0.1  $\mu$ sec (see Fig. 2-2a).

9. Now set channel B and D MODE switches to OFF. Notice that the M Unit switches between channels A and C only. Each channel conducts for about 1  $\mu$ sec and then is cut off while the other channel conducts for an equal time (see Fig. 2-2b). Chopping rate for each channel is now approximately 500 kc.

### GENERAL OPERATION

Any of the four amplifier channels can be used independently by rotating the appropriate MODE switch to one of the DC or AC positions and connecting the signal to be observed to the appropriate input. The following remarks apply equally to each channel.

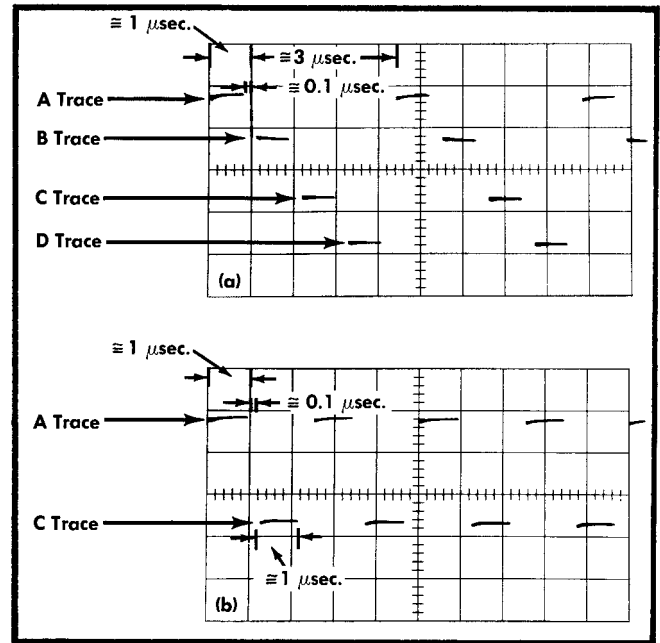

Fig. 2-2. (a) Chopping rate of each channel is approximately 250 kc, and (b) the chopping rate is about 500 kc. Switching rate is approximately 1 mc. Sweep rate of the oscilloscope is 1  $\mu$ sec/cm.

### Signal Connections

The signal(s) to be displayed is applied to the appropriate input connector on the front panel of the M Unit. For best results, following are some precautions you should observe when making the connections.

1. It is often possible to make signal connections to the M Unit with short-length, unshielded test leads. This is particularly true for high-level, low-frequency signals. When such test leads are used, you must also use a ground connection between the M Unit or oscilloscope chassis ground and the chassis of the equipment under test. Position the leads away from any stray electric or magnetic field source to avoid erroneous displays.
2. In many low-frequency applications, however, unshielded leads are unsatisfactory for making signal connections because of unavoidable pickup resulting from magnetic fields. Whenever possible, use shielded (coaxial) cables. Be sure that the ground conductors of the cables are connected to the chassis of both the oscilloscope and the signal source.
3. In broadband applications, it may be necessary to terminate the coaxial cable with a resistor or an attenuator equal to the characteristic impedance of the cable, to prevent resonance effects and ringing. It becomes more necessary to terminate the cable properly as the length of the cable is increased. The termination is generally placed at the oscilloscope end of the cable, although many sources require an additional termination at the source end of the cable as well.
4. As nearly as possible, simulate actual operating conditions in the equipment under test. For example, the equip-



ment should work into a load impedance equal to that which it will see in actual use.

5. Consider the effect of loading upon the equipment under test due to the input circuit of the M Unit. The input circuit can be represented by a resistance of 1 megohm ( $\pm 1\%$ ) shunted by a capacitance of approximately 47 picofarads. With a few feet of shielded cable, the capacitance may well be 100 picofarads. Where the effects of these resistive and capacitive loads are not negligible, you might want to use a probe in the manner described next.

### Use of Probes

An attenuator probe having a standard length cable (42" long) lessens both capacitive and resistive loading, but at the same time reduces sensitivity. The attenuation introduced by the probe permits measurements of signal voltages in excess of those that can be accommodated by the M Unit alone. When making amplitude measurements with an attenuator probe, be sure to multiply the observed amplitude by the attenuation of the probe (marked on the probe).

An adjustable probe capacitor compensates for variations in input capacitance from one plug-in unit to another. To assure the accuracy of pulse and transient measurements, this adjustment should be checked frequently.

To make this adjustment, set the oscilloscope calibrator controls for a calibrator output signal of suitable amplitude. Place the MODE switch for the channel in use to DC NORM. Touch the probe tip to the calibrator-output connector and adjust the oscilloscope controls to display several cycles of the waveform. Adjust the probe variable capacitor for best square-wave response, as shown in the right-hand picture of Fig. 2-3.

### Deflection Factor

The amount of vertical deflection produced by a signal is determined by the signal amplitude, the attenuation factor (if any) of the probe, the setting of the VOLTS/CM switch, and the setting of the VAR. GAIN control. Calibrated deflection factors indicated by the settings of the VOLTS/CM switch apply only when the VAR. GAIN control is set to

the CALIB. position. Serious errors in display measurements may result if the setting of this control is unintentionally moved away from this position.

The range of the VAR. GAIN control is approximately 2.5 to 1 to provide continuously variable (uncalibrated) vertical-deflection factors between calibrated settings of the VOLTS/CM switch. The VAR. GAIN control can be manually rotated continuously in either the clockwise or counter-clockwise direction, thus permitting the control to be set quickly to any desired position. The control has one detent position (CALIB.), which is the calibrated deflection factor setting.

Voltage measurements may be made directly from the oscilloscope screen by noting the calibrated VOLTS/CM switch setting for the applicable channel and the amount of vertical deflection on the crt. Multiply the deflection on the screen by the setting of the VOLTS/CM switch and the attenuation factor, if any, of the probe.

### MODE Switch

The MODE switch has five positions: DC NORM., AC NORM., OFF, DC INV. and AC INV. To display both the ac and dc components of an applied signal, set the MODE switch to one of the DC positions; to display only the ac component of a signal, set the MODE switch to one of the AC positions.

In the AC positions of the MODE switch, the dc component of the signal is blocked by a capacitor in the input circuit. The lower frequency limit (3-db point) of the M Unit is about 2 cps (0.2 cps if using a 10X attenuator probe). Therefore, some low-frequency distortion of signals with components below this frequency will result if the AC positions are used.

It may be desirable, at times, to invert the displayed waveform, particularly when using the multi-trace feature of the M Unit. With the MODE switch you can choose either a normal or inverted display, and either dc or ac coupling. In the DC- or AC-NORM. positions the displayed waveform has the same polarity as the input signal. In the DC- or AC-INV. positions the displayed waveform is inverted.

Placing the MODE switch to the OFF position turns the channel "off", disconnects the input signal, and excludes the channel from the electronic switching cycle.

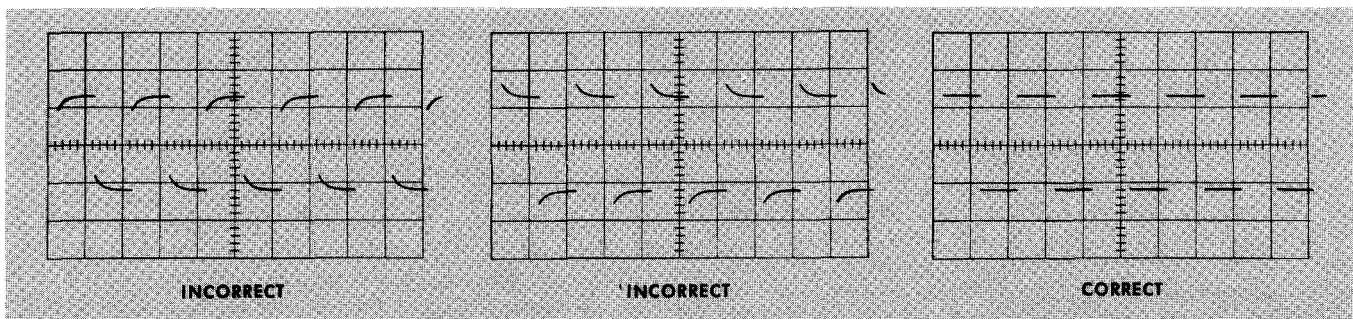

Fig. 2-3. Probe compensation waveforms.

## Operating Instructions—Type M

### ALTERNATE/CHOPPED Switch

For single-trace operation the ALTERNATE/CHOPPED switch is inoperative and no electronic switching of the channels occurs. For multi-trace operation the setting of the ALTERNATE/CHOPPED switch is important. The best setting to use depends on the repetition rate of the applied signals and whether or not they are related in time to each other.

In general, the ALTERNATE position is usually used with sweep rates above 10  $\mu$ sec and the chopped position with lower sweep rates. The ALTERNATE position is useful for observing unrelated or related signals of high repetition rate (usually above 100 kc), observing fast transients, and making phase and time-delay comparison measurements. The CHOPPED position is most useful for observing related low-frequency signals and for observing transients having a duration as short as 0.5 millisecond.

When determining the best mode of operation to use in a particular application, it is also necessary to choose the best triggering method. In the discussion that follows, triggering methods are described in more detail.

### Multi-Trace Triggering

Multi-trace triggering is divided into the following order: (1) External triggering using ALTERNATE and CHOPPED modes, (2) Internal triggering using ALTERNATE mode, and (3) Internal triggering using CHOPPED mode.

**External triggering using ALTERNATE and CHOPPED modes.** For multi-trace operation, it is usually best to trigger the time base with an external triggering signal which bears a fixed time relationship to the applied signals. A convenient source for obtaining the external trigger signal is from the "A" SIGNAL OUT connector. With an external triggering signal a stable display is more easily obtained and the true time or phase relationship between input signals can be determined.

To trigger from the channel A signal, simply connect a test lead between the "A" SIGNAL OUT connector on the M Unit and the Trigger Input connector on the oscilloscope. Then set the oscilloscope triggering controls for external triggered-sweep operation. To obtain a stable display, the signals applied to the other channels must be related in frequency to the channel A signal.

If the trigger signals have components above 10 kc, use the AC Fast or AC LF Reject triggering mode (if your oscilloscope has these positions). For lower frequency signals, use the AC or AC Slow triggering mode.

**Internal triggering using ALTERNATE mode.** If the time or phase relationship between signals is not critical, you can use internal triggering of the time base when the ALTERNATE/CHOPPED switch is set to ALTERNATE. In this mode of operation, the signals applied to the individual channels can be either related or unrelated in frequency. The oscilloscope Triggering Level control must be set at a point where the sweep will trigger on the display having the lowest amplitude. If the signals have components above 10 kc, use the AC Fast or AC LF Reject triggering

mode (if your oscilloscope has these positions). For lower frequency signals, use the AC or AC Slow triggering mode. In the AC Fast or AC LF Reject position, an rc filter is inserted into the trigger-input circuit of the oscilloscope which allows it to recover quickly from the dc level changes encountered with ALTERNATE sweep.

**Internal triggering using CHOPPED mode.** For multi-trace CHOPPED mode of operation, internal triggering should not be used unless the input signals are related to the chopped switching rate. If the signals are not related to the chopping rate, the sweep will try to trigger on the switching waveform rather than on the applied signals and will result in an unstable display. To obtain stable displays, externally trigger the sweep from the channel A signal. To do this, use the "A" SIGNAL OUT connector and set the oscilloscope controls for external triggered-sweep operation.

### DC Balance Adjustments

After the M Unit has been in use for a period of time, the trace may change position as the VAR. GAIN control is rotated. This is caused by slight changes in the operating characteristics of components in the M-Unit amplifier stages and resultant shift in operating potentials. To correct this condition in one or all channels proceed as follows:

1. Set the front-panel controls of the channel to be dc-balanced to these settings:

VOLTS/CM	Any position
MODE	DC NORM. or AC NORM.
VAR. GAIN	CALIB.
POSITION	Centered
ALTERNATE/CHOPPED	ALTERNATE

2. Set the oscilloscope sweep rate and triggering controls for a 0.5-millsec/cm free-running sweep.

3. With the POSITION control, position the trace to approximate center of the graticule.

4. Set the DC BAL. adjustment to the point where there is no trace shift on the crt as the VAR. GAIN control is rotated.

### Gain Adjustments

The gain adjustments should be checked periodically to assure correct vertical deflection factors, particularly when the M Unit is transferred from one oscilloscope to another. The following procedure describes a method for setting the gain of each channel when the M Unit is used with an oscilloscope having 4 centimeters of vertical scan. If the vertical scan of your oscilloscope is greater than 4 centimeters, use 100 millivolts from the oscilloscope calibrator and set the gain for a vertical deflection of exactly five centimeters. In other respects the procedure for setting the gain is the same.

To check the gain of each channel:

- Set the M Unit front-panel controls as follows:
 

VOLTS/CM (all channels)	.02
MODE (channel A)	DC NORM. or AC NORM.
MODE (channels B, C, and D)	OFF
VAR. GAIN (all channels)	CALIB.
POSITION (all channels)	Centered
ALTERNATE/CHOPPED	ALTERNATE
- Set the oscilloscope sweep rate and triggering controls for a 0.1-millisecond/cm free-running sweep.
- Apply a 20-millivolt peak-to-peak calibrator signal from the oscilloscope to all four channels.
- Set the channel A GAIN ADJ. control for a deflection of exactly one centimeter. (Use the A POSITION control to align the display with the horizontal graticule lines.)
- Place the channel A MODE switch to OFF and set the channel B MODE switch to DC NORM. Repeat step 4 using the channel B GAIN ADJ. and POSITION controls.
- Follow the procedure described in step 5 to adjust the gain of channels C and D.

## BASIC APPLICATIONS

The following paragraphs describe procedures for making voltage, phase, and time-delay measurements with the Type M Plug-In Unit and associated Tektronix oscilloscope. An application is also included using the Channel A Signal Output Amplifier as a preamp for observing low-level signals. No attempt has been made to describe any but the most basic techniques. Familiarity with the unit will enable the operator to apply the essence of these techniques to a wide variety of applications.

### Voltage Measurements

Following are three categories of voltage measurements that can be obtained with the Type M Unit: (1) peak-to-peak voltage of a displayed waveform, (2) dc level at some point on a signal, and (3) voltage comparison measurements. The specific examples that follow are intended to show the general procedure. These examples can be modified to suit any particular application.

**Peak-to-peak voltage of a displayed waveform.** To measure the peak-to-peak voltage of a displayed waveform, the M Unit MODE switch should usually be set to one of the AC positions. In these positions only the ac components of the input waveform are displayed on the crt. However, if the ac component of the input waveform is very low in frequency, it will be necessary to make voltage measurements with the MODE switch in one of the DC positions to prevent errors. After selecting the MODE switch position for your particular application, proceed as follows:

- Display the waveform over as large a portion (vertically) of the crt as possible by adjusting the appropriate VOLTS/CM switch.

- With the aid of the graticule, measure the vertical distance in centimeters between the two points on the waveform at which the voltage measurement is desired. Make sure the appropriate VAR. GAIN control is set to the CALIB. position.

In measuring signal amplitudes, it is important to remember that the width of the trace may be an appreciable part of the overall measurement. For this reason, you should consistently make all measurements from one side of the trace. This is particularly true when measuring signals of small amplitude. Notice in Fig. 2-4 that points *a* and *b* correspond to the bottom side of the trace. The measurement would be just as accurate if points *a* and *b* corresponded to the top side or center of the trace.

- Multiply the vertical distance between the two points by the setting of the appropriate VOLTS/CM switch and by the attenuation factor, if any, of the probe. This is the voltage between the two points of the waveform.

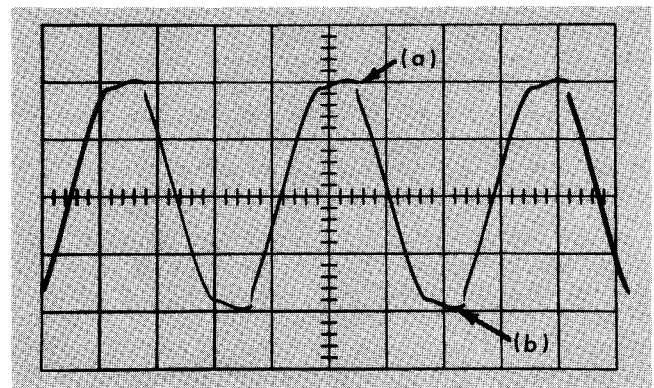

Fig. 2-4. Measuring peak-to-peak voltage.

As an example of this method, assume that using a 10X probe and a VOLTS/CM switch setting of .02, you measure a vertical distance of 4 centimeters as shown in the illustration. In this case, 4 centimeters times 0.02 volt/cm results in 0.08 volt. This voltage times the probe attenuation factor of 10 results in the true peak-to-peak voltage of 0.8 volt.

**DC level at some point on a signal.** The method used to measure the dc level at some point on a signal is virtually the same as the method described for measurement of peak-to-peak voltage. However, for dc-voltage measurements the M Unit MODE switch must be set to the DC NORM. position. Also, dc voltages are measured with respect to some potential (usually ground).

To measure the dc level at some point on a signal with respect to ground (see Fig. 2-5), proceed as follows:

- Set the MODE switch of the channel to which the signal will be applied to the DC NORM. position.
- Set the corresponding VOLTS/CM switch such that the expected voltage (at the channel input connector) is approximately one to four times the setting of the switch. Make sure the VAR. GAIN control is set to the CALIB. position.
- Set the oscilloscope triggering controls to produce a free-running trace.

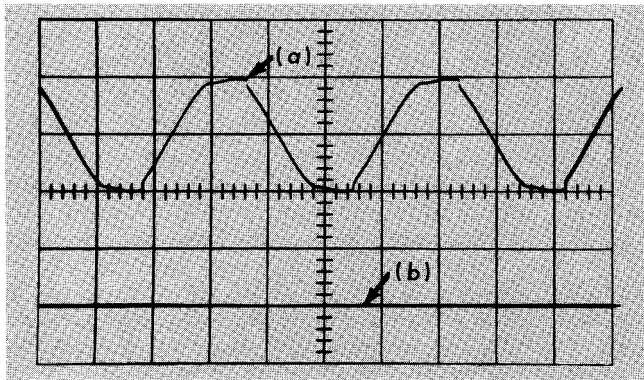

Fig. 2-5. Measuring a voltage with respect to some reference.

4. Touch the oscilloscope probe tip to a ground point, and with the appropriate POSITION control position the trace so that it lies along one of the horizontal lines of the graticule, such as *b* in Fig. 2-5. This line will be used as a ground reference line; its position in any given case will depend upon the polarity and amplitude of the input signal or dc level to be measured. Do not adjust the POSITION control after the reference line has been established.

As an alternative method, you can set the oscilloscope for automatic triggering and use the trace of an unused channel as a reference. To do this, ground the probe tip as described in step 4. Superimpose the trace of an unused channel on the trace of the channel to which the signal will be applied. After establishing the reference, do not move the POSITION controls for these channels.

5. Remove the probe tip from ground and connect it to the signal. Adjust the triggering controls for a stable display.

6. Measure the distance, in centimeters, from the ground reference line established in step 4 to the point at which the dc voltage level is desired, such as between *a* and *b* in Fig. 2-5.

7. Multiply this distance by the setting of the appropriate VOLTS/CM switch and the attenuation factor, if any, of the probe. This is the dc level of the point measured.

As an example, suppose the vertical distance between *a* and *b* is 4 centimeters when a 10X probe is used and the VOLTS/CM switch is set to .5. Multiply the distance between *a* and *b* (4 cm) by the VOLTS/CM setting (.5 volt/cm) and by the probe attenuation ratio (10). This shows the peak voltage level of the waveform with respect to ground to be 20 volts.

**Voltage comparison measurements.** For some applications you can establish a set of sensitivity values other than those selected by the VOLTS/CM switch. This is useful for comparing signals with a given reference. The following procedure describes how to set sensitivity values for channel A. The same procedure can be used for the other channels.

To establish a set of sensitivity values based upon a specific reference amplitude, proceed as follows:

1. Apply a reference signal of known amplitude to channel A and, with the corresponding VOLTS/CM switch and the VAR. GAIN control, adjust the amplitude of the display for an exact number of graticule divisions. Do not move the VAR. GAIN control after you have obtained the desired deflection.

2. Divide the amplitude of the reference signal (in volts) by the product of the deflection in centimeters (established in step 1) and the VOLTS/CM switch setting. The result is the sensitivity conversion factor.

$$\text{Sens. Conv. Factor} = \frac{\text{Reference signal amplitude in volts}}{(\text{Deflection in cm}) (\text{VOLTS/CM setting})}$$

3. To calculate the true sensitivity at any setting of the VOLTS/CM switch, multiply the VOLTS/CM switch setting by the sensitivity conversion factor obtained in step 2.

$$\text{True Sensitivity} = (\text{VOLTS/CM setting}) (\text{Sens. Conv. Factor})$$

True sensitivity values obtained for any setting of the A VOLTS/CM switch apply only to this one channel, and only as long as the VAR. GAIN control is not moved from the position to which it was set in step 1.

As an example, suppose the voltage amplitude of the reference signal applied to channel A is 30 volts, and the VOLTS/CM switch setting is 5. The VAR. GAIN control is adjusted to decrease the amplitude of the display to exactly 4 centimeters. With these values substituted in the formula for Sensitivity Conversion Factor and True Sensitivity, we have,

$$\text{Sens. Conv. Factor} = \frac{30}{(4) (5)} = 1.5$$

$$\text{True Sensitivity} = (5) (1.5) = 7.5 \text{ volts/cm}$$

As proof that the true sensitivity value thus obtained is correct we can take the product of 7.5 volts/cm and 4 centimeters of deflection. The result is 30 volts, which checks with the known amplitude of the reference voltage.

To make a comparison measurement, for example, suppose that a signal of unknown peak-to-peak amplitude is applied to channel A in place of the 30-volt reference signal. Suppose also that a signal to be compared causes a deflection of 2.7 centimeters at a VOLTS/CM switch setting of 2. Then the peak-to-peak amplitude of the signal can be determined as follows:

$$\text{P-P Signal Amplitude} = (\text{Sens. Conv. Factor}) (\text{Deflection in cm}) (\text{VOLTS/CM setting})$$

Substituting values just given we have

$$\text{P-P Signal Amplitude} = (1.5) (2.7) (2) = 8.1 \text{ volts}$$

### Phase Measurements

Phase comparisons of two to four signals of the same frequency can be made by making use of the multi-trace feature of the Type M Plug-In Unit. To make phase comparisons, proceed as follows:

1. Apply the reference signal to channel A; apply the signals to be compared to the other channels.

2. Connect a test lead between the "A" SIGNAL OUT connector on the M Unit and the External Trigger input

on the oscilloscope. Set the oscilloscope for external-triggered sweep operation.

3. Set the MODE switches to AC or DC NORM. depending on the type of coupling desired.

4. Set the ALTERNATE/CHOPPED switch to the ALTERNATE or CHOPPED position. In general, the ALTERNATE position is more suitable for high-frequency signals and the CHOPPED position is more suitable for low-frequency signals.

5. Set the VOLTS/CM switches for the desired display amplitude. Carefully center the signals vertically using the POSITION controls.

6. Set the oscilloscope time-base controls (includes the Variable Time/Cm control) so that one cycle of the reference signal occupies exactly 9 centimeters horizontally. Thus, each centimeter represents 40° of one cycle at this time-base setting (see Fig. 2-6).

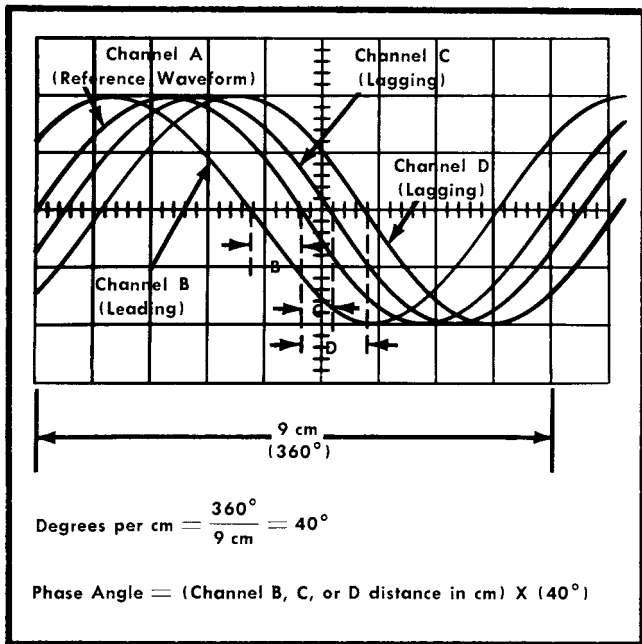

Fig. 2-6. Measurement of phase angles between electrical waveforms.

7. Measure the horizontal distance, in centimeters, between corresponding points on the reference waveform and each of the other waveforms. Note the distance for each channel and whether it is leading or lagging. To make each phase comparison measurement easier, switch the non-applicable waveforms off by setting the appropriate MODE switches to the OFF position until you need to display them.

8. For each distance measured, multiply the distance by 40° per centimeter to obtain the phase difference compared to the reference waveform.

For more precise measurements, you can increase the vertical sensitivity and the sweep rate established in steps 5 and 6, but do not change the setting of the oscilloscope Variable Time/Cm control. However, when you increase the sweep rate, you must consider this in your calculations.

For example, if you increase the sweep rate by a factor of 5, and then measure the distance between waveforms, each centimeter will represent 8° (40° ÷ 5) of a cycle. By doing this, you can measure phase angles up to 80° more accurately. When preparing to make the measurement, horizontally position the waveforms to points where the graticule markings aid in determining the exact distance. Fig. 2-7, for example, shows how the phase angle of channel B waveform can be computed using this method. Other phase-angle measurements can be determined using the same basic procedure.

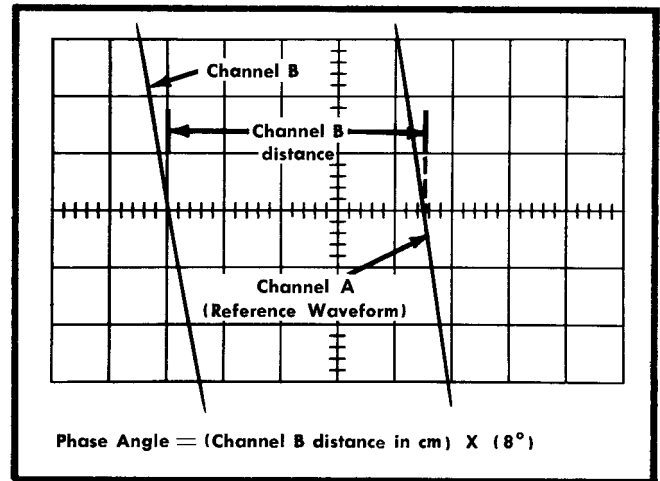

Fig. 2-7. Computing the phase angle when the oscilloscope 5X magnifier is on. Accurate phase-angle measurements within a range of 80° can be made using this method.

### Time-Delay Measurements

The calibrated sweeps of Tektronix oscilloscopes cause any horizontal distance on the screen to represent a definite known interval of time. Using this feature in combination with the multi-trace feature of the M Unit, you can measure the time lapse or delay between events displayed on the oscilloscope screen. This is done by the following method:

1. Follow the procedure outlined in the first five steps of "Phase Measurements".
2. Set the oscilloscope time-base controls for a calibrated sweep rate which will allow you to accurately measure the distance between waveforms.
3. Using the graticule, measure the horizontal distance between the reference waveform and each of the other waveforms. For most measurements the distance is usually measured between 50% amplitude points on the rising portion of the waveforms. To make the measurements between waveforms easier, switch off the waveforms not being measured.
4. Multiply the distance measured for each channel by the setting of the oscilloscope Time/Cm control to obtain the time interval. (Divide the apparent time interval by the magnification factor if sweep magnification is used.)

$$\text{Time Delay} = \frac{\text{Time/Cm switch setting} \times \text{Distance in cm}}{\text{Sweep magnification}}$$

## Operating Instructions—Type M

For example, assume that the Time/Cm switch setting is 2  $\mu$ sec, the Magnifier is set for 5X magnification, and you measure a horizontal distance of 5 centimeters between the leading edge of the reference waveform and the leading edge of the waveform displayed on another channel. For these conditions, 5 centimeters multiplied by 2 microseconds per centimeter results in an apparent time delay of 10 microseconds. The apparent time delay divided by 5 then results in an actual time delay of 2 microseconds.

### Channel A Signal Output Amplifier

The two-stage transistorized Channel A Signal Output Amplifier contained in the M Unit is designed primarily for use as an external trigger source using the channel A input signal. However, it can be used as a convenient, built-in, dc preamplifier for channels B, C or D when used within its capabilities.

As a dc low-level preamplifier, the Channel A Signal Output Amplifier has a gain of approximately 100 when referred to the signal amplitude at the channel A input connector. It has a bandpass of dc to 590 kc at  $-3$  db when working into an approximate impedance equivalent to 10 megohms paralleled by 50 pf. This impedance is equivalent to the following: a patch cord connected between the "A" SIGNAL OUT connector and the oscilloscope external trigger input connector (also serves to trigger the sweep), and a Tektronix P6006 Probe connected with the cable end to the channel B, C, or D input connector and the tip to the "A" SIGNAL OUT connector. Beyond 590 kc the frequency response of the amplifier rolls off gradually.

If the preamplifier is used to drive one of the channels directly, such as the case of a short patch cord substituted for the probe, it has to drive a capacitance of 82 pf. The bandpass of some M Units, when checked using this setup, was reduced to about 450 kc.

Other characteristics to consider are noise level, dc drift, and for sufficient signal to drive the oscilloscope external trigger input connector. The noise level at the

"A" SIGNAL OUT connector is equivalent to about a 20-millivolt peak-to-peak input signal. Noise level and dc drive are tolerable if a sensitivity less than 500  $\mu$ volts/cm is used. However, reliable triggering cannot be obtained unless the external trigger amplitude approaches or exceeds the minimum required amplitude of 0.2 volt.

As an example of this application, assume that a 2-millivolt calibrator signal is applied to the channel A input connector. This signal is amplified about 100 times by the Channel A Signal Output Amplifier, producing an amplitude of 200 millivolts at the "A" SIGNAL OUT connector. Then patch cords are connected from the "A" SIGNAL OUT connector to both the channel B input connector and the oscilloscope trigger-input connector, to apply the 200-millivolt signal to both points. The A VOLTS/CM switch is set to .02 and the B VOLTS/CM switch to .05. The B VAR. GAIN control is adjusted so that the waveform is exactly four centimeters in amplitude. This makes the calibrated B VOLTS/CM switch settings equivalent to their indicated value divided by 100. When the A VOLTS/CM is set to .02, the input signal is applied to the Channel A input connector, amplified by the Channel A Signal Output Amplifier, then connected to the Channel B input connector and read from the oscilloscope using the B VOLTS/CM switch. For the .05 setting, in this example, the sensitivity is 500  $\mu$ volts/cm.

If a probe is substituted in place of the patch cord to the channel B input connector, the calibrated B VOLTS/CM switch settings are equivalent to their indicated value divided by 10 or a maximum usable sensitivity of 2 millivolts/cm can be obtained.

When the B VOLTS/CM switch is set to .05 and patch cords are connected as described earlier, the noise amplitude equals about 20 millivolts on the 200-millivolt channel-B waveform. When the B MODE switch is set to one of its DC positions, you may have trouble positioning the waveform onto the crt using the B POSITION control unless the OUTPUT DC LEVEL control (an internal adjustment in the M Unit) is adjusted to a more exact setting. If this control needs to be adjusted, refer to step 17 in the Calibration portion of the manual. If ac coupling is used, exact adjustment of the OUTPUT DC LEVEL control is not necessary.

# SECTION 3

## CIRCUIT DESCRIPTION

### AMPLIFIERS

#### Introduction

The M Unit consists of four identical input amplifiers, a common output amplifier, and a signal-out amplifier for channel A. Since the input amplifiers are identical, the following description applies to all. Throughout the circuit-description discussion, you should refer to the block and circuit diagrams located near the back of this manual.

#### Input Coupling

The signal to be displayed is applied to the input cathode follower V5323 through one section of the MODE switch (SW5300, 1F) and the VOLTS/CM switch (SW5310). In the DC positions of the MODE switch, input coupling capacitor C5301 is bypassed with a direct connection. In the AC positions the signal must pass through C5301 so the dc component of the signal is blocked. In the OFF position the signal is disconnected.

#### Input Attenuation

The M Unit requires an input signal of 0.02 volt, peak-to-peak, to produce one centimeter of calibrated deflection on the crt. In order to satisfy this condition, and to make the instrument applicable to a wide range of input voltages, precision attenuation networks can be switched into the input circuitry by means of the VOLTS/CM switch SW5310. The voltage-attenuation ratios of these networks are  $X2\frac{1}{2}$ , X5, X10 and X100.

When the VOLTS/CM switch is in the .02 position, the signal is coupled without attenuation to the Input Cathode Follower, V5323. For the other settings of the VOLTS/CM switch, the attenuation networks are switched into the circuit, either singly or in tandem pairs, so that the input voltage to V5323 is always 0.02 volt for each centimeter of crt deflection when the VAR. GAIN control R5326 is set to the CALIB. position.

The attenuators are frequency-compensated voltage dividers. For low-frequency signals they are resistive dividers, and the degree of attenuation is proportional to the ratio of the resistances. This is because the impedance of the capacitors, at low frequencies, is high and their effect in the circuit is negligible. As the frequency of the

input signal increases, however, the impedance of the capacitors decreases and their effect in the circuit becomes more pronounced.

For high-frequency signals the impedance of the capacitors is low, compared to the resistance of the circuit, and the attenuators become capacitive voltage dividers. For these frequencies, the degree of attenuation is inversely proportional to the ratio of the capacitances. A variable capacitor in each attenuator (for example, C5308C in the  $X2\frac{1}{2}$  attenuator) provides a method for adjusting the capacitance ratios equal to the resistance ratios.

The variable capacitor at the input to each attenuator (for example, C5308B in the  $X2\frac{1}{2}$  attenuator) provides a means for adjusting the input capacity of the attenuator to a standard value of 47 picofarads. Similarly, C5317 provides a method of standardizing the input capacity when the VOLTS/CM switch is in the .02 position. In this manner, the probe, connected to the input connector, works into the same input capacity regardless of the setting of the VOLTS/CM switch. In addition to providing the same input capacity, the resistance values in the attenuators are chosen to provide the same input resistance (1 megohm) for each setting of the VOLTS/CM switch.

#### Input Amplifier

The Input Amplifier consists of two stages: Input Cathode Follower V5323 and the Paraphase Amplifier Q5324/Q5334.

**Input Cathode Follower V5323.** This stage employs a Nuvistor which is essentially a subminiature triode. Nuvistor V5323 presents a high-impedance, low-capacitance load to the input circuit and isolates the input circuit from the succeeding stages. The cathode of V5323 is long-tailed through R5323 to the -150-volt supply. With this configuration, stable gain is obtained, and large input signals can be handled without distortion.

C5318 and R5318 form a protection circuit in the grid circuit of V5323. These components prevent excessive grid current from V5323 in case a positive-going overload signal is inadvertently applied to the input connector. Positive-going signals passing through V5323 are prevented from damaging Q5324 by protective diode D5324. Negative-going signals cannot damage Q5324 because current flow in the transistor is limited to about 3 ma. R5316 and R5319 in the grid circuit of V5323 are parasitic suppressors.

**Paraphase Amplifier Q5324/Q5334.** This stage is a transistorized, emitter-coupled amplifier. In addition to amplifying the signal, the stage converts the single-ended

## Circuit Description—Type M

input signal at the base of Q5324 to a push-pull output signal between the two collector circuits. Push-pull gain of the stage is approximately 2.2. Both emitters are long-tailed (through R5325 and R5335) to the +100-volt supply for greater stability with respect to transistor parameters and temperatures.

There are two gain controls located in the common-emitter circuit of the Paraphase Amplifier. One is the VAR. GAIN control R5236 and the other is GAIN ADJ. control R5336, a front-panel screwdriver-adjust potentiometer. Both controls vary the emitter degeneration and thus affect the gain of the stage. The GAIN ADJ. is adjusted so that the amount of crt deflection agrees with the setting of the VOLTS/CM switch when the VAR. GAIN control is set to the CALIB. position.

The DC BAL. control R5332, a front-panel adjustment, is used to adjust the dc level of Q5334 so that its emitter will be at the same voltage as the emitter of Q5324 when no input signal is applied to the unit. With the emitters at the same voltage there will be no current through the VAR. GAIN control. With this configuration an adjustment of the VAR. GAIN control will not affect the dc level in the collector circuit of the Paraphase Amplifier stage, and will therefore not affect the positioning of the beam.

Collector loads R5324 and R5334 develop the output signal of Q5324 and Q5334. The output signal is push-pull and is applied to a gate consisting of four diodes—D5345, D5347, D5346 and D5348. During multi-trace operation a positive-going gating pulse is applied to the junction of R5345 and R5347. The pulse at this junction causes the diodes to conduct and the push-pull signal passes from the Input Amplifier, through the diode gate and MODE switch contacts, to the Output Amplifier.

If the MODE switch is set to either the AC- or DC-NORM. position, the signal passes through the diode gate and MODE switch directly to the Output Amplifier to produce a normal display on the crt. However, when the MODE switch is set to either the AC- or DC-INV. position, the switch reverses the signal-grid connections of V5364 and V5374 and inverts the displayed waveform. When the MODE switch is set to the OFF position, the Input Amplifier is disconnected from the Output Amplifier and no signals pass through the diode gate.

When all MODE switches are set to OFF, diodes D5360 and D5370 clamp the grids of V5364 and V5374 near ground, preventing the grids from moving toward -150 volts. In addition, the diodes provide a very convenient method for checking the dc balance of the Output Amplifier. With all MODE switches in the OFF position the grids are essentially connected together.

## Vertical Positioning

The POSITION control, connected between R5341 and R5343, changes the current through collector load resistors R5324 and R5334. With the control centered, the current through each load resistor, under no-signal conditions, is the same. When the control is moved to either end, a change of 2 ma per side occurs. This current change results in a positioning voltage range of approximately 300

millivolts at the transistor collectors. The voltage range corresponds to about  $\pm 10$  centimeters positioning range at the crt since direct coupling is employed.

## Output Amplifier

The Output Amplifier, which is a common amplifier for all channels, consists of two stages: Push-Pull Amplifier V5364/V5374 and Output Cathode Follower V5383.

**Push-Pull Amplifier V5364/V5374.** The Push-Pull Amplifier stage provides a total gain of about 5 for signals and dc-positioning voltages that arrive when the diode gate for the operating channel is gated "on" by the switching pulse from the Ring Counter. The gating pulse itself is not amplified because it is common mode and cancels out in the cathode circuit of the stage.

Static current drain in this stage is about 6 ma per side; 1.5 ma is screen current and 4.5 ma is plate current. Static plate voltage is about 65 volts.

Peaking inductors L5360 and L5370 provide necessary high-frequency compensation in the grid circuits of the stage. In the plate circuits variable inductors L5363 and L5373 compensate the stage for high-frequency attenuation caused by the tube and stray capacity. The m-derived sections of the variable inductors provide a means for adjusting the stage for optimum transient response.

A position range network consisting of R5377, R5378 and R5365 in the cathode circuits of this stage cancel any static imbalance for centering the traces. With the VERT. POS. RANGE control, R5378, all traces can be made to coincide as a group with the vertical system electrical center. Range of the VERT. POS. RANGE control is about 200 mv at each grid of V5383, equal to about a 4-centimeter change in trace position, 8 centimeters push-pull.

**Output Cathode Follower V5383.** The Output Cathode Follower stage operates much the same as the Input Cathode Follower stage. That is, it provides a high-impedance, low-capacitance load to the Push-Pull Amplifier stage, and a low-impedance driving source for the capacitance of the inter-connecting plug and the input of the main vertical amplifier in the oscilloscope.

Peaking coils L5384 and L5386 form a series-peaking circuit with the stray capacitance in their respective circuits. These peaking circuits are damped by the cathode impedance of each side of V5383. Due to the fairly large cathode resistors (9.1 k) employed, the cathode impedance is approximately equal to the reciprocal of the transconductance of the tube ( $1/G_m$ ). By varying the current through the tube, the H.F. PEAKING control can vary the transconductance, thereby varying the effect of the peaking circuits.

## Channel A Signal Output Amplifier

The Channel A Signal Output Amplifier Q5344 and Q5354 is a two-stage transistorized auxiliary amplifier for channel A only. It provides a dc-coupled signal obtained from channel A for external triggering purposes, particularly for use during multi-trace operation in the CHOPPED mode.



## SWITCHING CIRCUIT

The signal is taken from the junction of R5326 and R5327 located in the common-emitter circuit of Q5324 and Q5334. The R5326-R5327 junction is a convenient low-impedance point for extracting the signal without affecting the M-Unit bandwidth and with least pick up of switching transients when using the M unit in the CHOPPED mode.

With the VAR. GAIN control set to the CALIB. position, the signal amplitude at the junction is about 80% of that at the grid of V5323. At the base of Q5344, the signal amplitude decreases to about 60% of that at the grid of V5323. The gain of the Channel A Signal Output Amplifier is about 160; Q5344 has a gain of approximately 10 and Q5354 has a gain of about 16. The overall gain of 160 results in an output signal of approximately 2 volts at the "A" SIGNAL OUT connector for each centimeter of vertical deflection on the crt. Bandwidth of the amplifier is dc to about 1.0 mc  $-3$  db (750 kc  $-3$  db, S/N 101-2759), and the rolloff is long and gradual.

The OUTPUT DC LEVEL control R5354 is the current source for adjusting and matching the dc level at the "A" SIGNAL OUT connector to the level at the channel A input connector. Normally, when making the adjustment, the A input connector is grounded and the OUTPUT DC LEVEL control is adjusted to obtain a voltmeter reading of zero at the "A" SIGNAL OUT connector. This control compensates for variations between Nuvistors and the effects of tube aging. The high gain of the Channel A Signal Output Amplifier and the relatively wide variation in transconductance between Nuvistors makes the control somewhat sensitive. Therefore, the control should be adjusted carefully when matching dc levels. Exact zero volts is difficult to obtain and a setting within a few hundred millivolts of zero is adequate for triggering purposes. However, if this amplifier is used as a dc preamplifier, the control has to be adjusted more carefully for a setting less than a few hundred millivolts from zero.

### S/N 2760-up

Above serial number 2759, Q5344 is replaced with a double transistor. The A side of the transistor performs the same basic functions as did Q5344. The B half comprises a comparator circuit with A side.

When channel A was initially set up the DC BAL control was adjusted for no movement of the trace as the VAR GAIN control was turned away from its CALIB position. The GAIN ADJ control was then adjusted to provide the proper gain. When the above adjustments are made, there will exist a given potential on the base of Q5344A and the base of Q5344B. The OUTPUT DC LEVEL control is then adjusted for a zero volt dc level at the "A" SIGNAL OUT connector.

If the Type M is now moved to another oscilloscope and the DC BAL control is adjusted properly, the given potential on the bases of Q5344A and Q5344B will be close to those which existed the first time the OUTPUT DC LEVEL was adjusted. Since the OUTPUT DC LEVEL control is already adjusted for these potentials, the dc level at the "A" SIGNAL OUT connector is still close to ground.

### Ring Counter

The Ring Counter consists of Q6315, Q6325, Q6335 and Q6345 and associated circuitry. Each transistor controls one Input Amplifier channel. The Ring Counter is tetra-stable; that is, each of its four states is stable and a trigger from the Switching B.O. Q6350 during multi-trace operation is required to make it switch channels. When triggered, the Ring Counter performs the task of sequencing and gating the Input Amplifiers.

When only one channel is on (single-trace operation), Q6350 is inoperative and the Ring Counter remains switched on or "locked" on the one channel, keeping it on. When all channels are turned off (all MODE switches set to OFF), the Ring Counter is in a quiescent state.

In the following discussion the Ring Counter is described under four modes of operation. These are: (1) all channels off, (2) single-trace operation, (3) alternate multi-trace operation, and (4) chopped multi-trace operation.

**(1) All channels off.** With all MODE switches set to the OFF position, the Ring Counter is placed as close as possible to a quiescent or static condition. All transistors in the Ring Counter are reverse-biased except the one that is switched off last. Assume for this discussion that the channel A MODE switch was set to the OFF position last.

The base voltage for each transistor is determined by a matrix of three 10.1-k resistors located in each base circuit. Matrix currents through R6310, R6320, R6330, R6340 and R6360 hold all bases at about +6.5 volts. The common emitter bus is held at about +6.8 volts by the emitter current of Q6315 (channel A turned off last). The collector bus rests at about  $-7$  volts by the current drawn by Q6315 and the matrix circuits.

The voltage at the collector of Q6315 is held at about +3.7 volts by the current through Q6315; the remaining collectors are held at about  $-1.4$  volts. With three transistors cut off, the  $-1.4$  volts at the collectors of these transistors reverse bias their D5345/D5347 diodes. Channel A diodes D5345 and D5347 are forward biased by the +3.7 volts at the collector of Q6315, but no signals are passed since the MODE switch is set to OFF.

**(2) Single-trace operation.** When the channel A MODE switch is turned on, the voltage at the base of Q6315 decreases from about +6.5 volts to about +5.9 volts since the base is no longer connected to R6310. Current through Q6315 increases slightly, causing the collector voltage to change from +3.7 volts to about +4 volts. The voltage at the other collectors remains at about  $-1.4$  volts and the common collector bus drops slightly to about  $-6.9$  volts. The diode gate for channel A, being forward biased, couples the channel A signal from the Input Amplifier through the MODE switch to the Output Amplifier. The diode gates for the other channels remain reverse biased.

Total collector current for Q6315 is about 9 ma . . . 5 ma through R6317 and 4 ma through the channel A diode gate. The total current through R6316 is the sum of the base and collector current of Q6315.

## Circuit Description—Type M

Matrix currents through R6320, R6330, R6340 and R6360 reverse bias D6360 and forward bias D6352. D6352 sets the base level of Q6364. Transistor Q6350 is clamped into cutoff by emitter current through Q6364, thus preventing the Switching B.O. from operating. This same action also occurs when all channels are off, assuming that Q6315 is the conducting transistor.

Resistors R6319, R6329 and R6339 are series-connected parasitic suppressors. During single-channel operation, they prevent the conducting transistor in the Ring Counter from oscillating. This is accomplished by providing ample resistance in the feedback path existing from the collector of the conducting transistor through the MODE switches and back to the base of the same transistor.

**(3) Alternate multi-trace operation.** When two or more MODE switches are turned on, Q6350 is biased so that it can be triggered. (Biasing of Q6350 is explained in the subsequent description of the Switching B.O.) In the ALTERNATE position of the ALTERNATE/CHOPPED switch, the trigger to drive Q6350 is obtained by applying the sync trigger from the oscilloscope time-base generator via pin 16 of the interconnecting plug. The trigger is regenerated by the blocking oscillator action of Q6350, differentiated by C6352, and applied to the common-emitter bus in the Ring Counter.

The negative-going regenerated trigger, when applied to the emitter bus, drives all emitters in the negative direction. Since only one transistor in the Ring Counter conducts at any given time, it is the only one affected by the trigger.

If Q6315 is the conducting transistor when the regenerated trigger is applied to the emitter bus, the collector current of Q6315 is sharply reduced and the collector voltage goes quickly negative, producing a fast, negative-going collector pulse. This pulse is then coupled through "speed-up" capacitor C6317 and the channel A MODE switch contacts to the base of Q6325. The pulse is also coupled through the matrix resistors to the bases of the other transistors in the Ring Counter. The pulse applied to the other bases is of much lower amplitude and is not significant. However, the larger and faster pulse applied to the base of Q6325 drives Q6325 into conduction and a 6-volt positive-going gating pulse is produced at its collector. The gating pulse is applied to channel B diode gate and turns it on for the duration of the gate pulse.

Due to the matrix action, the positive-going gate pulse at the collector of Q6325 is coupled to the bases of the other transistors, tending to hold them in cutoff and completing the cutoff of Q6315. As stated previously, in multi-trace operation the trigger from Q6350 is required to make the transistors switch states. When the transistors in the Ring Counter switch states, they always switch in sequence, regardless of the setting of the ALTERNATE/CHOPPED switch. The important components that make sequential switching possible are "speed-up" capacitors C6317, C6327, C6337 and C6347. It is these capacitors that provide the means for coupling the pulse from the "on" transistor to the base of the following transistor in a sequential order. If a MODE switch is set to OFF, during multi-trace operation, the transistor controlled by the MODE switch is bypassed and excluded from the switching cycle.

**(4) Chopped multi-trace operation.** When the ALTERNATE/CHOPPED switch is set to the CHOPPED position and two or more channels are on, the Switching B.O. Q6350 becomes a trigger generator by operating in a free-running mode at a rate of approximately 1 mc. The 1-mc triggers generated by Q6350 drive the Ring Counter. Operation of the Ring Counter in this mode is the same as its operation in the multi-trace alternate mode.

## Switching Blocking Oscillator

The Switching Blocking Oscillator (Switching B.O.) Q6350, during single-trace operation, is inoperative to allow the desired channel to remain "locked on". During multi-trace operation, Q6350 operates in a triggered mode when the ALTERNATE/CHOPPED switch is set to ALTERNATE, and in a free-running mode when set to CHOPPED.

## S/N 825-up

**(1) Single-trace operation.** Assume all channels are on and that channels B, C, and D are about to be turned off. When the MODE switch for channel B is set to OFF, approximately 0.5 ma matrix current flows through R6320. When channel C and D MODE switches are set to OFF, total current flowing from R6320, R6330 and R6340 is about 1.4 ma. The total current is enough to starve the current path through D6360. Diode D6360 reverse biases and unclamps the junction where it is tied to R6360. Resistor R6360 is "long-tailed" to the +225-volt supply so that the current through it remains the same regardless of the operating mode.

When D6360 reverse biases, the voltage at the junction of D6360 and R6360 drops from about 12.9 volts to about 12.2 volts. The voltage decrease causes diode D6355 to conduct. D6355 conducting causes the emitter of Q6350 to become more negative than its base. Under these conditions, Q6350 is cutoff and will not operate regardless of the setting of the ALTERNATE/CHOPPED switch.

**(2) Multi-trace triggered operation.** When the ALTERNATE/CHOPPED switch is set to ALTERNATE, one side of the switch connects pin 8 of the interconnecting plug to ground, which grounds R6368 and the cathode of the oscilloscope sync amplifier. The sync amplifier differentiates and amplifies the positive-going sync trigger generated by the oscilloscope sweep-gating multivibrator at the end of each sweep cycle. The negative-going sync trigger produced at the plate of the sync amplifier is applied through pin 16 of the interconnecting plug to the junction of R6365 and R6366, located in the collector circuit of Q6364.

The other side of the ALTERNATE/CHOPPED switch disconnects +100 volts from the emitter circuit of Q6350. Current through R6353 and R6356 determines the emitter level of Q6350.

The sync trigger which is applied to the R6365/R6366 junction, coupled through D6362 to the base of Q6350 turns on Q6350 which was biased just into cutoff. The sync trigger is also at the collector of Q6364, however since the base, emitter, and collector of Q6364 are all at 13.6 volts, the transistor remains cutoff.

The signal at the anode of D6352 is a single regenerated negative-going pulse that occurs each time the sync trigger from the oscilloscope is applied to the Q6350 base circuit. This regenerating of the sync triggers standardizes the varying size and shape of the sync triggers originating from the various types of oscilloscopes. The regenerated trigger becomes a sharp negative-going spike when coupled through C6352 and is easily handled without jitter by the Ring Counter.

**(3) Free-running operation.** The switching B.O. free runs when two or more channels are on and the ALTERNATE/CHOPPED switch is set to CHOPPED. When the switch is in this position, one side of the switch disconnects pin 8 of the interconnecting plug from ground disabling the oscilloscope sync amplifier and connects one side of R6364 to ground.

The other side of the ALTERNATE/CHOPPED switch connects +100 volts to a voltage divider consisting of R6362 and R6364. This voltage divider makes 35 volts available for the collector of Q6364.

The 35 volts at the collector of Q6364 causes D6362 to be reverse biased. With D6362 reverse biased, Q6364 is just into cutoff. Since both Q6350 and Q6364 are now in cutoff, the voltage divider of R6353 and R6356 starts charging C6355, C6356 and C6352. The charging of these three capacitors continues until the anode of D6352 is elevated positive enough to cause D6352 and Q6350 to conduct. When Q6350 starts to conduct, current through T6350 induces a negative-going voltage which is applied to the base of Q6350.

This negative-going voltage causes Q6350 to conduct more and more heavily until Q6350 is in saturation. When Q6350 is saturated the change in current through T6350 ceases. Since the base of Q6350 no longer has a negative-going voltage applied to it, it starts positive toward the 13.6 volt supply voltage.

The anode of D6352 has a large amount of capacitance tied to it which must change its charge if the anode is to change potential. The anode of D6352 is therefore very slow in changing its potential. The cathode goes positive more rapidly than the anode and reverse biases D6352. The anode of D6352 starts charging positive at a rate determined by R6353 and R6356, charging C6355, C6356 and C6352. When the three capacitors and the anode of D6352 are positive enough for D6352 and Q6350 to again conduct, the cycle repeats.

When the base of Q6350 starts positive toward the 13.6 supply voltage after saturation, it overshoots the 13.6 supply voltage because of the collapsing field of T6350. This positive overshoot is caught by the base-emitter junction of Q6364, turning it on. The collector of Q6364 now goes negative, producing a negative pulse which is capacitively coupled to the Blanking Amplifier in the oscilloscope. Since this pulse occurs delayed from the actual time of switching, it blanks the CRT at the same time as the switching transient reaches the deflection plates after being delayed in the vertical amplifier of the oscilloscope.

## SN 101-824

**(1) Single-trace operation.** Assume all channels are on and that channels B, C, and D are about to be turned off. When the MODE switch for channel B is set to OFF,

approximately 0.5 ma matrix current flows through R6320. When channel C and D MODE switches are set to OFF, total current flowing from R6320, R6330 and R6340 is about 1.4 ma. The total current is enough to starve the current path through D6360. Diode D6360 reverse biases and unclamps the junction where it is tied to R6360. Resistor R6360 is "long-tailed" to the +225-volt supply so that the current through it remains the same regardless of the operating mode.

When D6360 reverse biases, the voltage at the junction of D6360 and R6360 drops from about 12.9 volts to about 12.2 volts. The voltage decrease causes diode D6352 to conduct. The drop across D6352 and that across the base-emitter junction of Q6364 essentially cancel. Q6364 emitter current flowing through R6354 sets the emitter level for Q6350. Under these conditions, Q6350 is cutoff and will not operate, regardless of the setting of the ALTERNATE/CHOPPED switch. Thus, chopping-rate switching transients, which might interfere with the usefulness of single-trace displays, cannot occur, and triggers are not generated.

**(2) Multi-trace triggered operation.** When the ALTERNATE/CHOPPED switch is set to ALTERNATE, one side of the switch connects pin 8 of the interconnecting plug to ground, which grounds R6368 and the cathode of the oscilloscope sync amplifier. The sync amplifier differentiates and amplifies the positive-going sync trigger generated by the oscilloscope sweep-gating multivibrator at the end of each sweep cycle. The negative-going sync trigger produced at the plate of the sync amplifier is applied through pin 16 of the interconnecting plug to the junction of R6367 and C6364, located in the collector circuit of Q6364.

The other side of the ALTERNATE/CHOPPED switch disconnects divider resistors R6365 and R6366 from the emitter circuit of Q6350. The divider is now connected to the switch end of R6367 to supply an operating potential for the oscilloscope sync amplifier. Since the divider is disconnected from the emitter circuit of Q6350, current through R6355, R6353, R6354 and Q6364 determines the emitter level of Q6350.

When more than one channel is turned on, matrix currents to R6360 decrease. Diode D6360 becomes forward biased and supplies the current path to R6360. The voltage at the junction of D6360 and R6360 rises from about +12.2 volts to about +12.9 volts and reverse biases D6352. The clamping action of Q6364 holds Q6350 cutoff.

The sync trigger, applied to the R6367/C6364 junction, is coupled through C6364, R6364 and C6351 to the collector circuit of Q6350. The sync trigger is not applied to the collector of Q6364, however, because D6364 is reverse biased. To provide a load and a complete circuit for Q6364 during alternate operation, the collector of Q6364 ties to R6368 by forward biasing D6368. The switch end of R6368 connects to ground through the ALTERNATE/CHOPPED switch.

With the negative-going sync trigger applied to the collector circuit of Q6350, current flows through T6350 primary and into C6350. The varying magnetic flux in the primary induces a negative-going voltage at the base of Q6350 and starts the blocking oscillator action. This action continues until Q6350 is driven into saturation and collector current ceases to increase. Toroid T6350 field collapses

## Circuit Description—Type M

around the secondary, driving the base in a positive direction in excess of that needed to turn off the transistor. The base and emitter return to their original level and transistor Q6350 remains cut off until the next sync trigger arrives to repeat the cycle.

The signal at the emitter of Q6350 is a single regenerated negative-going pulse that occurs each time the sync trigger from the oscilloscope is applied to the Q6350 collector circuit. This regenerating of the sync triggers standardizes the varying size and shape of the sync triggers originating from various types of oscilloscopes. The regenerated trigger becomes a sharp negative-going spike when coupled through C6352 and is easily handled without jitter by the Ring Counter.

**(3) Free-running operation.** The Switching B.O. free runs when two or more channels are on and the ALTERNATE/CHOPPED switch is set to CHOPPED. When the switch is in this position, one side of the switch disconnects pin 8 of the interconnecting plug from ground, disabling the oscilloscope sync amplifier.

The other side of the ALTERNATE/CHOPPED switch disconnects the R6365/R6366 divider from R6367 and connects it to the emitter circuit of Q6350. Transistor Q6350 base-emitter junction becomes slightly forward biased. Diode D6360 is still forward biased and D6352 reverse biased. As soon as Q6350 conducts, the regenerative action of T6350 drives Q6350 rapidly into saturation. During this action, C6353 charges rapidly through the low emitter impedance.

At saturation, Q6350 collector current is constant and the T6350 field collapses. The collapsing field generates a positive-going backswing signal at the base, and the base returns quickly to its original level. Capacitor C6353 discharges through R6353 and the emitter returns to its original positive potential. When this happens, Q6350 conducts again, repeating the cycle. The repetition rate of the Switching B.O. is approximately 1 mc and is determined mostly by the R6353-C6353 time constant.

The negative-going signal at the emitter of Q6350 is coupled through C6352 to drive the Ring Counter. The signal at the base of Q6350 is a negative-going pulse with a duration of about 0.2 microsecond. The pulse ends with a positive-going backswing caused by the inductive kick in T6350. Normally, the backswing is undesirable. However, during chopped-mode multi-trace operation the backswing is useful as a blanking pulse to blank out the switching transients on the displayed waveform.

The positive-going backswing at the base of Q6350 drives D6352 into conduction. The diode serves two purposes during chopped-mode multi-trace operation—to limit the amplitude of the backswing, and to couple the backswing to the base of Q6364.

## S/N 101-824

### Chopped-Mode Blanking Amplifier

During multi-trace operation when the ALTERNATE/CHOPPED switch is set to CHOPPED, the Chopped-Mode

Blanking Amplifier Q6364 amplifies and inverts the backswing signal. The Q6364 collector circuit, during this mode of operation, has the following configuration. The ALTERNATE/CHOPPED switch grounds the switch end of collector load resistor R6364. The other end of R6364 is connected to the collector through D6364, which is forward biased because Q6364 is conducting. Diode D6368 is reverse biased since its cathode return ties to +100 volts within the oscilloscope.

The signal developed across R6364 is coupled through C6364 and pin 16 of the interconnecting plug to the blanking amplifier in the oscilloscope time-base generator circuit. From there it is applied to the cathode of the crt via the CRT Cathode Selector switch. The signal blanks the beam during the switching-time interval occurring between channels. Blanking the beam during this time prevents the unwanted switching transient from appearing on the displayed waveform.

During either single-trace or multi-trace chopped-mode operation, diode D6368 is reverse biased when the M Unit is used with a single-beam or a Type 555 dual-beam oscilloscope. When the M Unit is used with a Type 551 dual-beam oscilloscope having a multi-trace plug-in unit in the other plug-in compartment, D6368 remains reverse biased when the other unit operates in a chopped mode, to isolate the two plug-in units. If the other unit in a Type 551 operates in an alternate mode, pin 8 is grounded and D6368 is forward biased. Although D6368 is forward biased, the diode has no important function during this mode of operation.

When the ALTERNATE/CHOPPED switch is set to ALTERNATE, diode D6364 is reverse biased. This prevents sync triggers from getting to the collector of Q6364, and prevents Q6364 from loading down the incoming sync.

## HEATER CIRCUIT

The heaters in the Type M Plug-In Unit are supplied with direct current from the +100-volt regulated supply in the oscilloscope. This prevents the possibility of 60-cycle cathode modulation, which might result if the heaters were supplied with alternating current.

Power for the heater circuit (+75 v at 150 ma) is obtained from pin 15 of the interconnecting plug. For those oscilloscopes employing Delaying Sweep, the heaters of two of the tubes in the Delaying Sweep Generator are connected in series with the heater circuit of the M Unit to provide the necessary 25-volt drop. In those instruments employing only one Sweep Generator, a resistor connected between the heater string and the +100-volt bus provides the required drop.

The heater circuit also provides constant voltage sources for many circuits in the M Unit. The +13.6 volts developed across Zener diodes D5392 and D5393 (D5390 S/N101-3479) goes to the circuit of Q5344, Q5354, Q6350 and the base circuits of the transistors in the Ring Counter. The +6.3 volts developed across Zener D5391 goes to the base circuits of Q5334 (four channels). (S/N 101-824—the +38 volts goes

to the emitter circuits of Q6364 and Q6350.) The +50 volts goes to the plate circuit of V5323 (four channels) and the +69 volts goes to the plate circuit of V5364 and V5374.

The series-connected heaters of the tubes do not supply any current for the +50- and +69-volt sources; they simply act as a low-impedance divider to "fix" the voltages. Current (15 ma) is supplied to the +38-volt source (S/N 101-824), however. This current is conveniently obtained by the dif-

ference in heater current drawn by the Nuvistors (135 ma) and the current drawn by the remaining tubes (150 ma).

The series-connected heaters result in a total drop of about 61 volts. This drop, subtracted from the +75-volt source, leaves approximately 14 volts where it is applied across D5392 and D5390 (D5390 S/N 101-3479). The Zener diodes clamp the voltage to 13.6 volts,  $\pm 2\%$  (12.6 volts,  $\pm 5\%$ —S/N 101-3479).



# SECTION 4

## MAINTENANCE

### PREVENTIVE MAINTENANCE

The M Unit is a stable instrument, and will require complete calibration very infrequently. However, to be certain that the unit is operating properly at all times, the calibration of the unit should be checked after each 500-hour period of operation (or every six months if the unit is used intermittently). A complete step-by-step procedure for calibrating the unit and checking its operation is given in the Calibration section of this manual.

### Visual Inspection

Many potential and existent troubles can be detected by a visual inspection of the unit. For this reason, a complete visual check should be performed if the unit becomes inoperative, or needs repair or recalibration. Apparent defects may include loose or broken connections, damaged connectors, improperly seated tubes or transistors, scorched or burned parts, and broken terminal strips. The remedy for these troubles is readily apparent, except for heat-damaged parts. Heat damage to parts is often the result of other, less apparent troubles. It is essential to determine the cause of overheating before replacing the damaged parts.

### COMPONENT REPLACEMENT

#### General

Parts replacement information is contained in this portion of the manual. Because of the circuit configuration, replacement of certain parts, such as the VOLTS/CM switches, variable inductors, transistors or tubes, will require recalibration of the instrument to insure proper operation. Refer to section 5 for calibration instructions.

#### Switches

If a switch is defective and needs repair or replacement, use care in unsoldering and disconnecting the leads.

Single wafers on wafer-type switches are not normally replaced. If a wafer is defective, the entire switch should be replaced. Some switches may be ordered from the factory either unwired or wired with components mounted, as desired. Refer to the Parts List to find the unwired and wired switch part numbers.

When soldering the leads to one of the wafer-type switches, do not let solder flow around and beyond the rivet on the switch terminal. Otherwise the spring tension of the switch contact can be destroyed.

### Soldering Precautions

In the production of Tektronix instruments, a special silver-bearing solder is used to establish a bond to the ceramic terminal strips. This bond can be broken by repeated use of ordinary tin-lead solder, or by the application of too much heat. However, occasional use of ordinary solder will not break the bond if too much heat is not applied.

It is advisable to have a stock of solder containing about 3% silver if you frequently perform work on Tektronix instruments. This type of solder is used in printed circuitry and should be readily available. It may also be purchased directly from Tektronix in one-pound rolls (order by part number 251-514).

Because of the shape of the terminals on the ceramic terminal strips, it is advisable to use a small diameter wedge-shaped tip on your soldering iron when installing or removing parts from the strips. A wedge-shaped tip allows you to apply heat directly to the solder in the terminals and reduces the amount of heat required. It is important to use as little heat as possible. Fig. 4-1 shows the correct shape for the tip of the soldering iron. Be sure to file smooth the surfaces of the tip before tinning. This prevents solder from building up on rough spots where it can quickly oxidize.

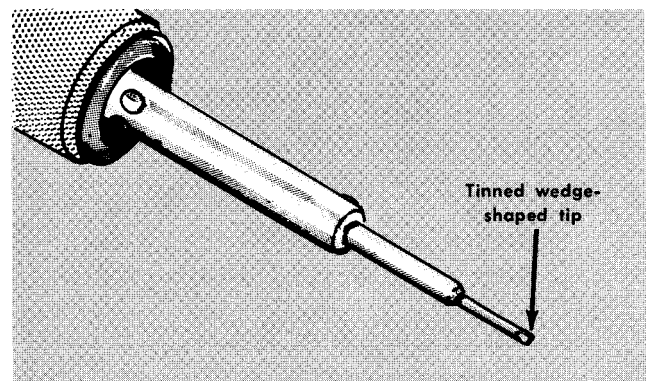

Fig. 4-1. Soldering iron tip properly shaped and tinned.

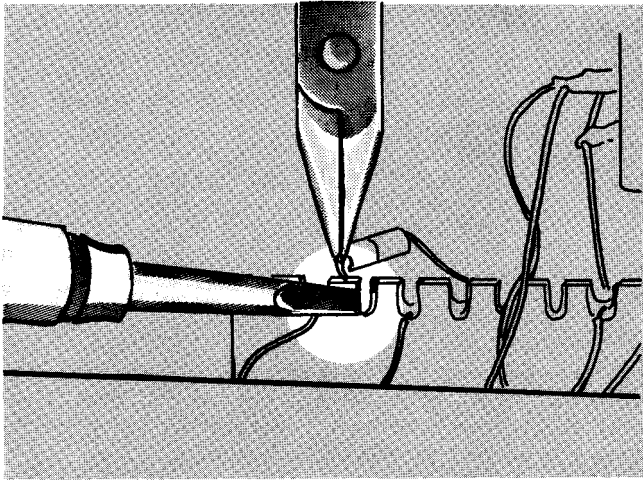

Fig. 4-2. Correct method of applying heat when unsoldering or soldering to a ceramic strip.

When removing or replacing components mounted on the ceramic strips, the procedure can be summed up as follows:

1. Use a soldering iron having a rating of about 40 to 60 watts. The soldering iron tip should have a shank diameter of approximately  $\frac{1}{8}$  inch for precision soldering in tight spots.
2. Prepare the tip of the iron as shown in Fig. 4-1. Tin only the wedge portion of the tip, using solder containing 3% silver.
3. Apply one corner of the tip to the notch where you intend to unsolder the lead (see Fig. 4-2).

**CAUTION**

If the tip of the iron is placed partly in the notch, do not twist the iron as this could chip or break the ceramic strip.

4. Apply only enough heat to melt the solder and remove the lead. If long-nose pliers are used to grip the lead to remove it, use the very tip of the pliers to prevent drawing away too much heat.
5. When resoldering the lead, apply enough heat to make the solder flow freely.

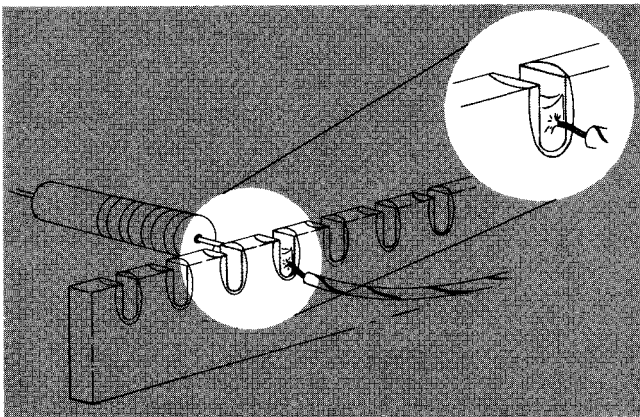

Fig. 4-3. A slight fillet of solder is formed around the wire when heat is applied correctly.

6. Do not attempt to fill the notch on the strip with solder; instead, apply sufficient solder to cover the wire adequately and to form a slight fillet on the wire, as shown in Fig. 4-3.

In soldering to metal terminals (interconnecting plug, pins on a tube or a transistor socket) a similar technique should be employed. Prepare the soldering iron as outlined and apply the iron to the part to be soldered. Allow the joint to heat sufficiently to permit the solder to flow freely and to form a smooth, slight fillet around the wire.

If the lead extends beyond the solder joint, clip the excess as close to the solder joint as possible. Remove all wire clippings that fall in the chassis.

To hold down interconnecting leads, or leads from components which are not adversely affected by heat during the soldering process, use a short length of wooden dowel with ends shaped as shown in Fig. 4-4. In soldering to terminal pins mounted in plastic rods or in soldering leads from thermo-sensitive components, such as diodes and transistors, it is necessary to use some form of "heat sink". A pair of long-nose pliers (Fig. 4-5) makes a convenient tool for this purpose.

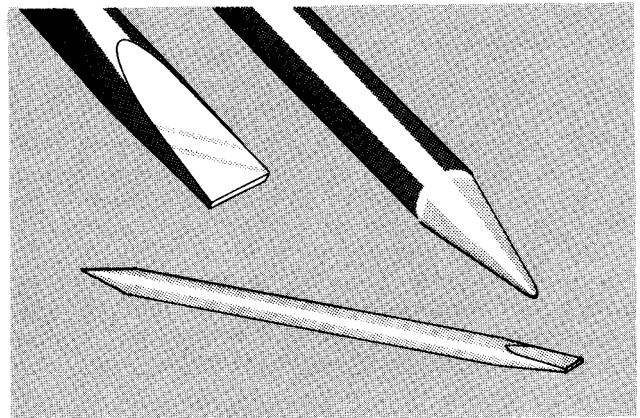

Fig. 4-4. A soldering aid constructed from a  $\frac{1}{4}$ -inch wooden dowel.

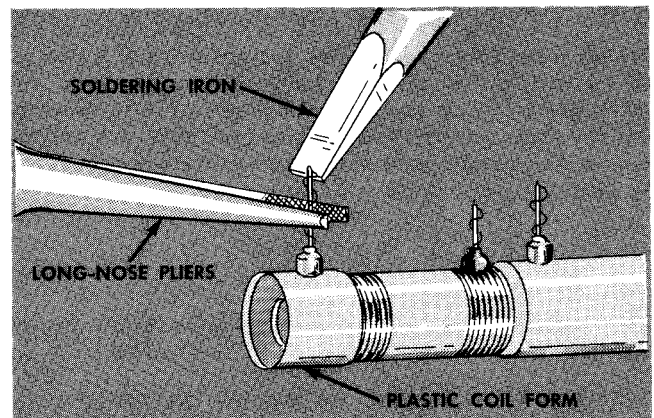

Fig. 4-5. Soldering to a terminal mounted in plastic. Note the use of the long-nose pliers between the iron and coil form to absorb the heat.



## Ceramic Terminal Strips

To remove a ceramic terminal strip, unsolder all components and connections, then pry the strip, with yokes attached, out of the chassis. An alternative method is to use diagonal cutters to cut off one side of each yoke (without damaging the spacer) to free the strip. After removing the strip, the remainder of each yoke can be easily extracted from the chassis with a pair of pliers. The yokes need not be salvaged since new ones are furnished with new strips. The spacers, however, may be reused.

To install a new strip, place the spacers in the chassis holes, insert the yoke pins through the spacers, and press down on top of the strip above the yokes. Use a plastic or hard rubber mallet, if necessary, to seat the yokes firmly. Be sure to tap above the yokes to keep from placing too great a strain on the strip. Fig. 4-6 illustrates the way parts fit together. If desired, the extending portion of the yoke pins may be cut off to within  $\frac{1}{8}$  inch of the lower end of the spacers.

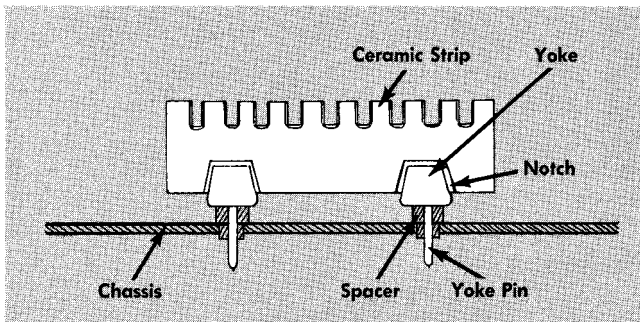

Fig. 4-6. Installation of a ceramic terminal strip.

Observe the soldering precautions described previously when soldering the leads to the strip.

## OBTAINING REPLACEMENT PARTS

### Standard Parts

Replacements for all parts used in the M Unit can be purchased directly from Tektronix, at current prices. Many of the components, however, are standard electronic parts that can usually be obtained locally. Before purchasing a part, be sure to consult the Parts List to determine the tolerance and rating required. The Parts List gives the values, tolerances, ratings and Tektronix part numbers for all components used in the unit.

### Special Parts

In addition to the standard electronic components mentioned in the previous paragraph, special parts are also used. These parts are manufactured or selected by Tektronix to satisfy particular requirements, or manufactured especially for Tektronix by other companies. These parts and most mechanical parts should be ordered directly from

Tektronix since they are normally difficult or impossible to obtain from other sources. All parts can be obtained through your local Tektronix Field Engineering Office.

## TROUBLESHOOTING

### General Information

This portion of the manual will aid you in troubleshooting the M Unit in the event that trouble develops. When troubleshooting, correlate the information in this section with information in other sections of the manual.

No attempt is made to give a complete step-by-step procedure for finding the cause of each possible type of trouble. Instead, an attempt is made to outline a troubleshooting guide. This guide provides a means for determining the probable cause of a trouble from symptoms observed.

A block diagram and complete schematic diagrams are contained at the rear of this manual. Reference designation of each component and voltages, waveforms, and test points are shown on the schematic diagrams.

All wiring in the M Unit is color coded to simplify circuit tracing.

### Test Points

Certain major test points are shown on the circuit diagrams and in Fig. 4-7. A test point is indicated by the numbered circles with an arrow pointing to the location of the test point in the circuit. Test points aid in troubleshooting and calibrating the unit. Waveforms and/or voltages are shown at each test point on the circuit diagrams. The conditions under which the waveforms and voltages were obtained are also indicated on the diagrams.

Test points are numbered consecutively starting with the diagram of the 4-Channel Switched Amplifier. Numbers increase from left to right across the page and continue from left to right across the Channel Switching Circuit diagram. The numerical arrangement of the test points should make it easy to find any particular test point.

### Preliminary Troubleshooting

Before troubleshooting, check front-panel controls to determine if the settings are proper for your particular application. If you are in doubt as to the proper settings of the controls and their function, refer to the Operating Instructions section. If you determine that a trouble definitely exists, proceed to isolate the trouble by making the following preliminary checks:

#### 1. Oscilloscope or M Unit

When following a troubleshooting procedure, it is assumed that the oscilloscope used with the M Unit is operating normally. This is not always the case. If in doubt, check the operation of the oscilloscope before attempting to troubleshoot the M Unit. Troubles occurring in the oscilloscope can usually be detected by substituting another plug-in unit for the M Unit (such as another M or CA Unit).

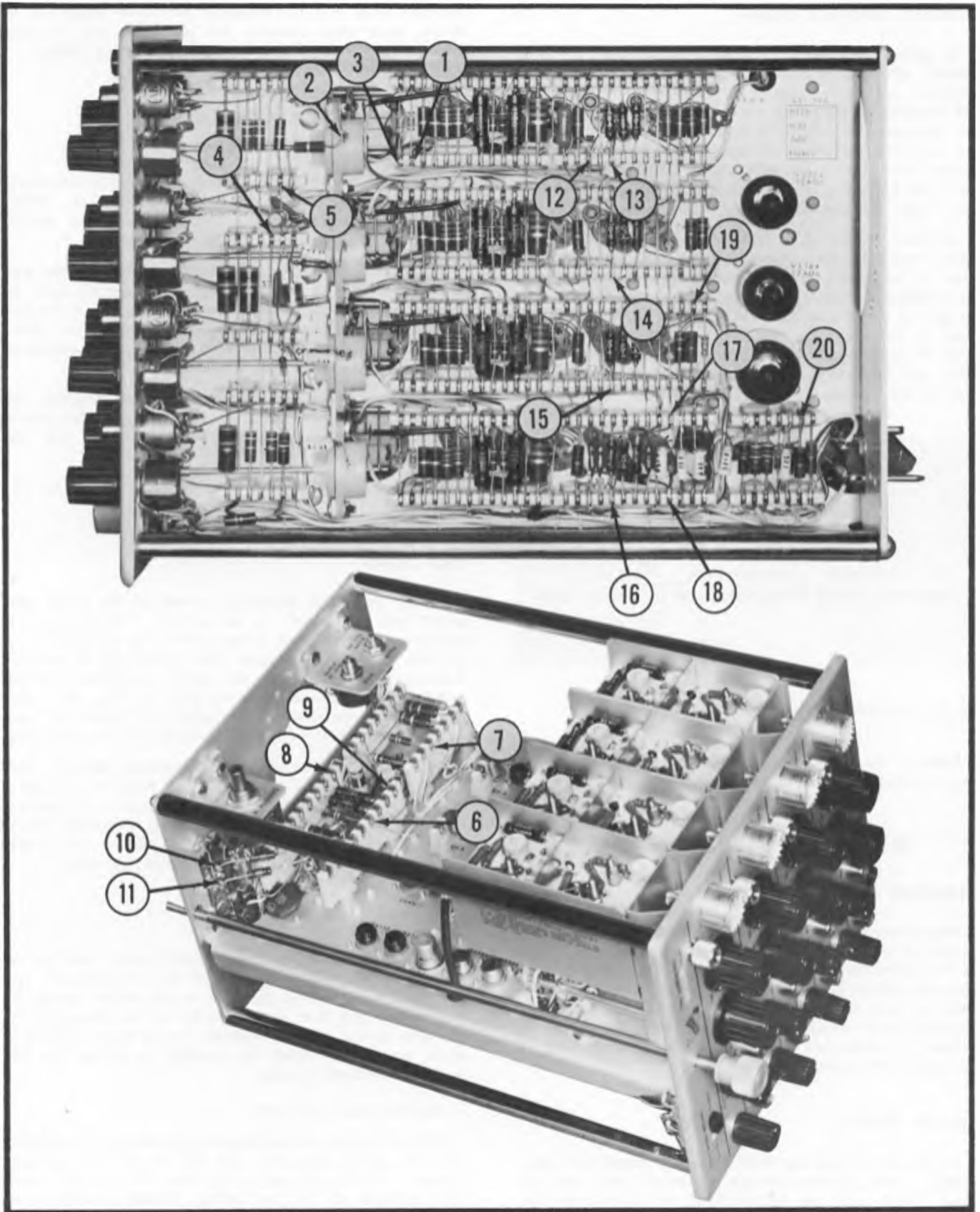

Fig. 4-7. Right-side view and left-rear portion of the M Unit showing the location of all test points.

Substituting an M or CA Unit is suggested because either of these units aids in isolating such troubles as loss of sync or improper chopped-mode blanking to either the oscilloscope or the plug-in unit.

## 2. Visual Operation Check

A good procedure to follow when the trouble has been isolated to the M Unit is to make a careful visual check of the unit as described earlier.

If no trouble is visible, apply an input signal to all four channels and observe the crt for proper waveshapes. Operate the front-panel controls to see what affect they have on the waveforms. The normal or abnormal operation of each control will indicate the type of trouble that exists. Once the symptoms can be observed, the faulty circuit containing the trouble can usually be isolated more readily.

## Troubleshooting Procedures

This portion of the manual contains a suggested troubleshooting technique, hints, and symptoms. The symptoms contain troubleshooting procedures and probable causes of the symptom.

**Troubleshooting Technique.** When circuit troubleshooting, a satisfactory technique is as follows:

(a) First, signal trace by using a calibrated oscilloscope of proper bandwidth to assure accurate displays and measurements. For example, when signal tracing through the Channel Switching Circuit to locate the cause of improper electronic switching of channels, use a test oscilloscope having calibrated time base settings and a bandwidth of 5 megacycles or more. Consider the loading effect, if any, of the probe, and be certain the probe is properly compensated.

(b) When an improper waveform is isolated to a stage, substitute for the tube or transistor (whichever is employed) in the defective stage. If this does not restore the proper waveform, proceed to check the diodes (if used in the stage), check voltages and, if necessary, make resistance checks until the exact cause of the trouble is found. Resistance checks in transistorized stages are easier to make when the transistors are removed from their sockets. When measuring resistances in circuits employing diodes, consider the polarity of the meter leads.

(c) If you have replaced a defective component and substituted for tubes or transistors, return the good tubes or transistors to their sockets. Such a procedure, if followed, results in less recalibration of the M Unit upon completion of the servicing.

**Troubleshooting Hints.** The following hints are included to aid you in avoiding certain pitfalls, and to speed up tube and diode selection. Transistors, if they meet manufacturer's specifications, do not require selection. If you are substituting any of the tubes or diodes mentioned in the hints when troubleshooting or calibrating the M Unit, use the associated information to make selection easier.

## CAUTION

Do not substitute tubes or Nuvistors when the M Unit is operating, as this will open the filament series circuit. Some of the regulated voltages along the series circuit will rise, causing serious damage to the unit.

(a) When replacing V5383, choose a tube that has good dc balance between halves. To do this, connect a shorting strap between test points 8 and 9 and note the amount of deflection from the vertical-system electrical center. Choose a tube which causes the trace to shift no more than 2 cm from the electrical center.

(b) When replacing V5364 or V5374, choose a tube that is closely dc balanced to the other. To do this, connect a shorting strap between test points 6 and 7. Try to bring the trace back to the screen by rotating the VERT. POS. RANGE control. If the trace does not return, reverse the tubes and try again. If reversing the tubes does make the trace appear, try another tube or pair of tubes and repeat the procedure. Remember that V5383 must have good dc balance before you can select V5364 and/or V5374 for proper dc balance.

(c) Nuvistors require selection to find one that will give the DC BAL. control range of adjustment. To select V5323, monitor the voltage at pin 8 of V5323. Choose a Nuvistor which produces a meter reading of 1.25 to 1.75 volts. Then, refer to steps 7 and 8 in the Calibration section of the manual to check the Nuvistor for excessive grid current and microphonics.

(d) Diodes D5345, D5347, D5346, and D5348 should be checked for matched pairs (D5345 and D5347; D5346 and D5348). A matched pair will insure that the flat top portions of the chopped-mode four-trace waveform will be as flat as possible. To match diodes, measure the forward and reverse resistances of each replacement diode. Find a pair that has similar resistance measurements.

**Symptoms.** The symptoms that follow are those that could happen when certain troubles occur. Since it is impossible to list every kind of symptom that could happen, those that are included here provide the basis or guide for analyzing others not described.

Procedures for isolating "trouble" to improperly adjusted front-panel controls are not included. See the Operating Instructions (Section 2) if you are in doubt about proper control settings.

### 1. Loss of All Traces

For the traces to be visible on the crt, the dc output voltage at test points 10 and 11 must be essentially equal—that is, within a fraction of a volt. As little as a 0.2-volt difference between these two points may position the beam above or below the range of visibility.

The dc output voltages depend on the dc balance of the Output Amplifier. Since the Output Amplifier is dc-coupled throughout, a condition anywhere between input and output that unbalances the output voltage more than 0.2 volt may cause a loss of all traces.

## Maintenance—Type M

One cause of dc imbalance is improper adjustment of the VERT. POS. RANGE control. Check the adjustment by performing step 3 in the Calibration procedure. Another cause could be imbalance due to a defective tube. Substitute for V5364, V5374, and V5383. Repeat step 3 in the Calibration procedure.

Other causes of imbalance are defective resistors, shorted or leaky capacitors, or open peaking coils. To isolate the cause of imbalance, a step-by-step procedure must be employed.

The procedure for isolating the cause of imbalance is accomplished by shorting together corresponding points on opposite sides of the Output Amplifier, starting at the output and working back toward the input. For example, set the oscilloscope time-base and triggering controls to obtain a 0.1-millisecond/cm free-running trace. Short test points 10 and 11 together. The voltages at these points will now be equal and the trace will appear at or near the center of the crt. The position of the trace is the vertical-system electrical center. From this point, the shorting strap can be moved back in successive steps to test points 8 and 9, and 6 and 7.

In following this procedure, a point will be reached where the trace cannot be made to appear when corresponding sides of the Output Amplifier are shorted together. When this occurs, the defect has been isolated to the stage in which these points are located. For example, if the trace appears when test points 8 and 9 are shorted together but does not appear when points 6 and 7 are shorted together, an open peaking coil L5363 or L5373 is a possible cause of trouble.

There is a possibility that the loss of all traces may be due to a defective heater circuit. This condition can be determined by observing the tubes in the M Unit for heater glow. If no glow is observed, it will most likely be due to an open heater in one of the tubes. Other possibilities are shorted capacitors C5390, C5392, C5394 and C5395.

### 2. Loss of Trace, One Channel

During multi-trace operation, if the trace for one channel cannot be positioned on the crt, it would indicate a dc imbalance in the Input Amplifier of that channel. Since the Input Amplifier is dc-coupled, a similar procedure to that given for the previous symptom would apply here. In addition, a good procedure to follow is to compare your results with the other Input Amplifier channels. Transistors and Nuvistors in a channel that is operating normally can be interchanged with those in the inoperative channel as part of the procedure given in steps b and c.

- a. Short together test points 1 and 3. If the trace does not appear, the trouble lies between the collectors of Q5324/Q5334 and the control grids of V5364/V5374. Check (for open diode) D5345, D5346, D5347, or D5348.
- b. If trace appears when shorting test points 1 and 3 together, short together the bases of Q5324 and Q5334. If trace does not appear, check for trouble in the Paraphase Amplifier stage Q5324 and Q5334, including the POSITION control circuitry.

- c. If trace appears when shorting the bases of the transistors together but disappears when jumper is removed, check for trouble in the base circuits of Q5324 and Q5334.

### 3. Inability to Position Trace, One Channel

If the trace for one of the channels cannot be vertically positioned with the appropriate POSITION control, some defect that is rendering this control inoperative is indicated. For example, check for an open POSITION control R5342.

### 4. Abnormal Positioning Range, One Channel

If the POSITION control for one channel must be set to an abnormal setting to position the trace on the screen, check for a shorted diode D5345 or D5347.

### 5. Interacting POSITION Control, Multi-trace Operation

If the POSITION control for one channel affects the positioning of other channels, check for a shorted diode D5346 or D5348.

Another symptom caused by the same trouble is that the POSITION controls require a setting approximately 90° from midrange to position the traces on the screen.

### 6. Loss of Two Traces, Alternate Mode

During four-trace operation when the ALTERNATE/CHOPPED switch is set to ALTERNATE, if only two abnormally wide traces appear, check the CHOPPED position. If four traces are displayed and they are also abnormally wide, set the oscilloscope sweep rate so that you can determine the chopping rate. If it is approximately 3 mc, check for an open diode D6360.

### 7. Loss of Three Traces, Alternate or Chopped Mode

During four-channel operation, if only one trace appears for either setting of the ALTERNATE/CHOPPED switch, this would indicate trouble in the Ring Counter, Switching B.O., or Chopped Mode Blanking Amplifier. The trouble can be further isolated by proceeding as follows:

- a. Observe waveforms at test point 17.
- b. If waveforms are normal, check voltages at test points 12 to 17 in the Ring Counter. Troubleshoot the circuit where an abnormal reading is found. Substitute for the transistors in the Ring Counter.
- c. If test point 17 waveforms are abnormal, replace Q6350 and Q6364. If this does not restore normal operation, then check D6352 and D6360.
- d. If substitution of transistors and diodes does not restore normal operation, proceed with voltage checks at test points 18 and 19 to determine if these circuits contain the trouble. If further isolation of the trouble is necessary, detailed voltage and resistance checks will have to be made.

### 8. Loss of Three Traces, Alternate Mode

If only one trace appears when the ALTERNATE/CHOPPED switch is set to ALTERNATE during four-trace

operation, this indicates trouble in the Switching B.O. and Chopped Mode Blanking Amplifier, or a loss of sync from the oscilloscope time-base generator. Isolate the trouble by proceeding as follows:

- a. Observe waveform at test point 20.
- b. If waveform is normal, check Q6350 and associated circuitry.
- c. If waveform is abnormal, check the ALTERNATE/CHOPPED switch, and the circuitry between test point 20 and the oscilloscope time-base generator. If the single trace on the crt is abnormally wide, and you note that sine waves at a frequency of about 3 mc are superimposed on the waveform at test point 20, the Switching B.O. is oscillating at an abnormal synchronized rate. Probable cause of this trouble is an open diode.

### 9. Loss of Three Traces, Chopped Mode

If only one trace appears when the ALTERNATE/CHOPPED switch is set to CHOPPED during four-channel operation, the Switching B.O. stage is possibly at fault. To check, proceed as follows:

- a. Observe the waveform at test point 18.
- b. Absence of the waveform at test point 18 indicates that the Switching B.O. is not oscillating and that further checks are necessary.
- c. Replace Q6350. If this does not restore normal operation, check diodes D6352 and D6360.
- d. If normal operation is not obtained after performing step c, check voltages at test points 18 and 19. Any abnormal voltage here (or at any other point in the Q6350 circuitry) should indicate the circuit at fault.

### 10. Aberrations on Four Traces, Chopped Mode

If the traces appear thicker than normal when the ALTERNATE/CHOPPED switch is set to CHOPPED, the Switching B.O. is probably oscillating at a considerably higher rate than 1 mc. Check the waveform at test point 17. If the repetition rate of the triggers is about 3.6 mc, check for an open diode.

### 11. No Waveform Display, One Channel

If a horizontal trace is present for one of the channels, but you are unable to display a waveform, an open circuit or a short exists somewhere in the signal path of that channel. However, since the trace is present, the defective component is one that does not affect the dc balance of the Input Amplifier.

Signal trace the circuitry between the input connector and the collectors of Q5324 and Q5334, and check as possible causes for a shorted or open VOLTS/CM switch, or a shorted coax lead between the VOLTS/CM switch and the grid of V5323.

### 12. Insufficient Gain, All Channels

If the vertical deflection on the crt no longer corresponds to the calibrated value, and this condition affects

all channels, a change in gain characteristics of the Output Amplifier is indicated. If tubes are causing the trouble, it will most likely be tubes V5364 and V5374. It is unlikely that V5383 will affect the gain to any degree.

The gain of the Differential Amplifier stage V5364 and V5374 can be decreased by an increase in the value of the cathode resistors, or if R5377 is open.

### 13. Insufficient Gain, One Channel

If there is insufficient gain in one channel only, the trouble lies in the Input Amplifier for that channel. The trouble can be further isolated by checking different settings of the VOLTS/CM switch to determine if gain is normal for some positions and not for others. A gain trouble can affect more than one switch position because the attenuators are "stacked" in some positions.

If gain is correct in some VOLTS/CM switch positions but not others, isolate the defective attenuator according to the information in Table 4-1.

TABLE 4-1

VOLTS/CM Switch Setting	Attenuator Network
.02	None
.05	X2 $\frac{1}{2}$
.1	X5
.2	X10
2	X100

If gain is incorrect for only one position of the VOLTS/CM switch, the trouble will be in that switch position. Check for a defective switch contact.

If the gain is incorrect for all positions of the VOLTS/CM switch, replace V5323, Q5324 and Q5334. If you do not have spares available, interchange components with another channel for a quick check. If gain is not restored, signal trace with a test oscilloscope to isolate the trouble. Check for open cathode or emitter resistors in the Input Amplifier stage. When checking the emitter resistors, consider the VAR. GAIN and GAIN ADJ. controls as possible causes.

### 14. Insufficient Output from "A" SIGNAL OUT Connector

If the gain is normal for channel A, but the signal at the "A" SIGNAL OUT connector is not normal, signal trace from test point 2 to the connector. Replace Q5344 if a gain of about 10 is not obtained for this stage. Replace Q5354 if a gain of about 16 is not obtained for this stage.

If substituting for either or both transistors in the "A" Signal Out Amplifier does not restore normal operation, proceed with voltage and resistance checks.

### 15. Waveform Distortion, Signal Channel

Any distortion that may be produced by the M Unit will be of a high-frequency nature. (Since the M Unit is dc-coupled from input to output, when the MODE switches are set to the DC positions, there will be no low-frequency distortion unless one or more stages in the Input Amplifier conduct heavily. If this occurs, other types of distortion will

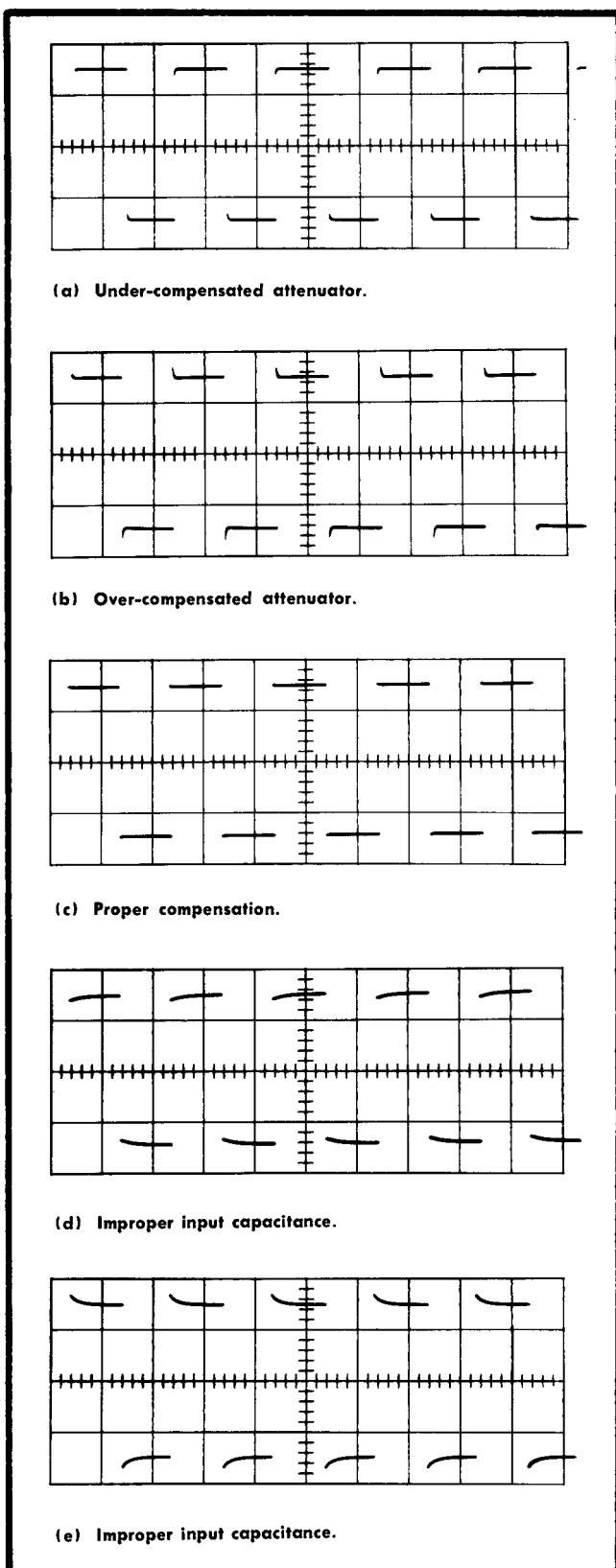

Fig. 4-8. Displays showing the effect of maladjusted high-frequency attenuator- and input-capacitance trimmers. Signal generator: Tektronix Type 105 Square-Wave Generator. Signal frequency: 1 kc. Oscilloscope sweep rate: 0.5 millisec/cm.

also occur and it will be necessary to signal trace through the Amplifier at fault to isolate the cause of the trouble. When signal tracing, always consider the loading effect of the probe.)

High-frequency distortion generally manifests itself in either a rolloff or an overshoot at the leading corner of a fast-rise step function, such as a squarewave. Fig. 4-8(a) shows an example of rolloff caused by an improperly adjusted attenuator network in the VOLTS/CM switch, and Fig. 4-8(b) shows an example of overshoot. Fig. 4-8(c) shows a typical waveform obtained when the M Unit is functioning normally, and all compensation adjustments are proper. If the relative time constant of the distortion is long compared to Fig. 4-8, (a) and (b), and is similar in appearance to Fig. 4-8, (d) or (e), such distortion can occur when using an attenuator probe.

To isolate high-frequency distortion in the Input Amplifier, it is important to know if the distortion occurs when a fast-rise signal is applied directly to the input connector, or through an attenuator probe. If distortion occurs when the signal is applied directly to the input connector, use the procedure described in part (a). If distortion occurs when applying the signal through a probe, refer to part (b).

(a) Distortion—Signal applied directly. Set the VOLTS/CM switch to .02. Apply a fast-rise squarewave from a low-impedance signal generator, such as a Tektronix Type 105 Square-Wave Generator, to the input connector. If it is necessary to attenuate the signal use a resistive (non-capacitive) divider. If distortion occurs, troubleshoot the circuitry external to the switch. Try substituting for V5323, Q5324 and Q5334. If you do not have spares available, use the ones in another channel for testing. If Nuvistor or transistor substitution does not restore normal operation, make voltage and resistance checks to locate defective components.

If no distortion occurs when the VOLTS/CM switch is set to .02, try the .05, .1, .2 and 2 positions. If distortion occurs using one of these positions, check for an improper attenuator compensation adjustment. Refer to steps 15 and 16 in the Calibration procedure. If distortion occurs when the VOLTS/CM switch is set to .5, 1, 5 or 10, check the switch contacts.

(b) Distortion—Signal applied through an attenuator probe. Apply a fast-rise squarewave (from a Tektronix Type 105 Square-Wave Generator or equivalent) through sufficient attenuation to the attenuator probe tip. The signal amplitude at the probe tip should be about 600 millivolts. Connect the cable end of the probe to the input connector of a channel which is operating normally. Set the VOLTS/CM switch to .02 and properly compensate the probe.

Disconnect the cable end of the probe and connect it to the input connector of the channel at fault. Set the VOLTS/CM switch to .02. If distortion is observed using this position of the VOLTS/CM switch, check the input-capacitance trimmer adjustment C5317 by referring to step 15 in the Calibration procedure.

Set the VOLTS/CM switch successively to the .05, .1, .2 and 2 positions. If distortion occurs at one or more of these positions, the appropriate input-capacitance trimmer may need adjusting. Refer to step 15 in the Calibration procedure.

### 16. Waveform Distortion, All Channels

If you note waveform distortion on all channels when the same fast-rise step signal is applied to each, you can assume the distortion is produced in the Output Amplifier.

Examples of high-frequency distortion can be seen by referring to Fig. 5-5, (b), (c) and (d), in the Calibration procedure. If the distortion appears similar to one of these illustrations, the usual cause is an improper adjustment of the peaking coils (L5363 and L5373). If adjustment is necessary, perform step 19 in the Calibration procedure.

An improperly adjusted H.F. PEAKING control produces a distortion similar to that produced by maladjusted peaking coils, but such distortion will only be visible at the faster sweep rates. Shorted or partially shorted peaking coils are often a source of high-frequency rolloff; this condition is generally produced by hot solder falling on the coils. Be especially careful when soldering around any of the peaking coils.

### 17. Switching Transients Visible in Chopped Mode

If the switching transients are visible during multi-trace chopped-mode operation, the trouble is in the Chopped Mode Blanking Amplifier Q6364 stage (if you are using the M Unit with an oscilloscope that has chopped-mode blanking circuitry). Use a test oscilloscope to observe and monitor the waveform at test point 20. Substitute for Q6364. If normal operation is not obtained, check for an open or shorted diode. If normal operation is not restored, check voltages and resistances throughout the stage.

### 18. Short Circuit

If the oscilloscope used with the M Unit must be turned off because the M Unit causes resistors in the oscilloscope power supply to overheat, remove the M Unit from the plug-in compartment. Use Table 5-1 in the Calibration procedure for resistance checks to isolate the trouble. When you have found the cause of the trouble, replace the damaged resistors (if any) in the oscilloscope. Recheck the M Unit under operating conditions.





# SECTION 5

## CALIBRATION

### INTRODUCTION

A complete procedure for checking the operational standards and calibration of the Type M Plug-In Unit is provided in this section of the manual. The steps are arranged in logical sequence to avoid unnecessary repetition.

When performing some steps in succession using a particular setup (such as steps 11 through 14), you may prefer to go through the four steps with the signal applied to one channel. Using this method, you can turn the other MODE switches to OFF while completing the steps. You can then repeat the steps for each of the other channels. This method reduces changing the signal connections as often, the trace intensity is brighter, and the traces of the other channels are not displayed. As familiarity with the procedure and operation of the M Unit increases, such deviations from the procedure in the manual may aid in shortening the calibration time.

#### NOTE

Calibration steps may be performed out of sequence, or a single step may be performed individually. However, it may be necessary to refer to the preceding step(s) and/or preliminary procedure for additional setup information, such as the proper front-panel control settings, test equipment required, and interconnecting cables or leads required and their connections.

These step-by-step instructions furnish an orderly approach for isolation of minor operational deficiencies that may not be apparent during normal usage. Consequently, this procedure should be used in conjunction with any maintenance and troubleshooting system to locate such deficiencies. Obscure symptoms, if any, usually show up when performing steps 1 through 14. The remaining steps check and aid in restoring the M Unit to optimum frequency response and risetime.

If a minor malfunction becomes apparent at some point in the procedure, it is not usually necessary to locate its cause immediately before continuing to the next step. Additional symptoms revealed by performing further steps will frequently simplify the task of locating the trouble.

Test equipment used in a particular step should be left connected at the end of that step unless instructions state otherwise. Similarly, controls not mentioned are assumed to be in positions they were in at the conclusion of the preceding step.

### EQUIPMENT REQUIRED

The following equipment is required to perform a complete calibration of the Type M Plug-In Unit.

- (1) Oscilloscope, Tektronix Type 540-, 550-, or \*580-Series, or equivalent. The oscilloscope must be properly calibrated and have a vertical amplifier risetime of 10 nsec or less. Oscilloscope control settings for a Type 541A Oscilloscope are listed in the procedure; corresponding control settings should be used if a different oscilloscope is used.
- (2) Square-wave generator, Tektronix Type 105 or equivalent. Required specifications: 13-nsec or less risetime; output frequencies of approximately 100 cps, 250 cps, 1 kc, 2.5 kc, and 10 kc; output amplitude variable from 10 to 100 volts across a 600-ohm internal load.
- (3) Square-wave generator, Tektronix Type 107 or equivalent. Required specifications: 3-nsec or less risetime; output frequency of approximately 450 kc; output amplitude variable from approximately 0.1 volt to at least 0.2 volt when cable is terminated in 50 ohms.
- (4) Volt-ohmmeter (VOM). Sensitivity of at least 5000  $\Omega/v$  at full deflection.
- (5) 47-pf Input Time Constant Standardizer. (Tektronix Part No. 011-0030-00 UHF or 011-0068-00 BNC.)
- (6) Plug-In Extension. (Tektronix Part No. 013-0055-00.)
- (7) 50-ohm (nominal impedance) coaxial cable, 42 inches long. (Tektronix Part No. 012-0001-00 UHF or 012-0057-00 BNC.)
- (8) Two 50-ohm cable terminations. (Tektronix Part No. 011-0045-00 UHF or 011-0049-00 BNC.)
- (9) 50-ohm 5×T attenuator. (Tektronix Part No. 011-0032-00 UHF or 011-0060-00 BNC.)
- (10) Tektronix Type P6006 Probe, or equivalent. Required specifications are: bandpass, dc to 20 mc; attenuation, 10×; input capacitance, approximately 10 pf. (Tektronix Part No. 010-0125-00 UHF or 010-0127-00 BNC.)

\* Type 81 Plug-In Adapter required for use with Type 580-Series oscilloscope.

## Calibration—Type M

### (11) Miscellaneous:

- 1—Alligator clip and cover.
- 1—3-inch jumper lead with 4" insulated test prods connected to each end.
- 1—Patch cord, 18 inches long, with banana plug-and-jack combination at each end (Tektronix Part No. 012-0031-00.)
- 1—Test lead, approximately 4 feet long, with banana plug connected to one end. For example, GC Electronics Co. Part No. 33-484.
- 4—Patch cords, 6 inches long, with banana plug-and-jack combination at each end. (Tektronix Part No. 012-0024-00.)
- 1—Screwdriver, for screwdriver-adjust potentiometers.
- 1—Alignment tool, consisting of a handle (Tektronix Part No. 003-0307-00), nylon insert with wire pin (Tektronix Part No. 003-0308-00), and a hexagonal core insert (Tektronix Part No. 003-0310-00).

(12) 4—\*BNC to binding post adapters (Tektronix Part No. 103-0033-00).

(13) 1—UHF male to BNC female adapter (Tektronix Part No. 103-0015-00).

(14) 1—BNC male to UHF female adapter (Tektronix Part No. 103-0032-00).

\*Needed only if instrument has BNC connectors.

## PRELIMINARY PROCEDURE

Before installing the M Unit in the oscilloscope, make a careful visual inspection of the wire dress. This is particularly important if any soldering has been done to the unit. Then make the resistance-to-ground checks indicated in Table 5-1. Fig. 5-1 shows the location of the interconnecting plug, internal adjustments, and test points called out in the procedure.

Connect the Plug-In Extension to the M Unit and install the unit with the extension in the oscilloscope vertical plug-in compartment. Turn on the oscilloscope and allow 15 minutes for warm up and complete stabilization. Preset the Type 541A Oscilloscope (or equivalent) front-panel controls as follows:

Horizontal Display	Normal
Time/Cm	1 $\mu$ Sec
Variable Time/Cm	Fully clockwise (calibrated)
Triggering Mode	AC
Trigger Slope	+Int.

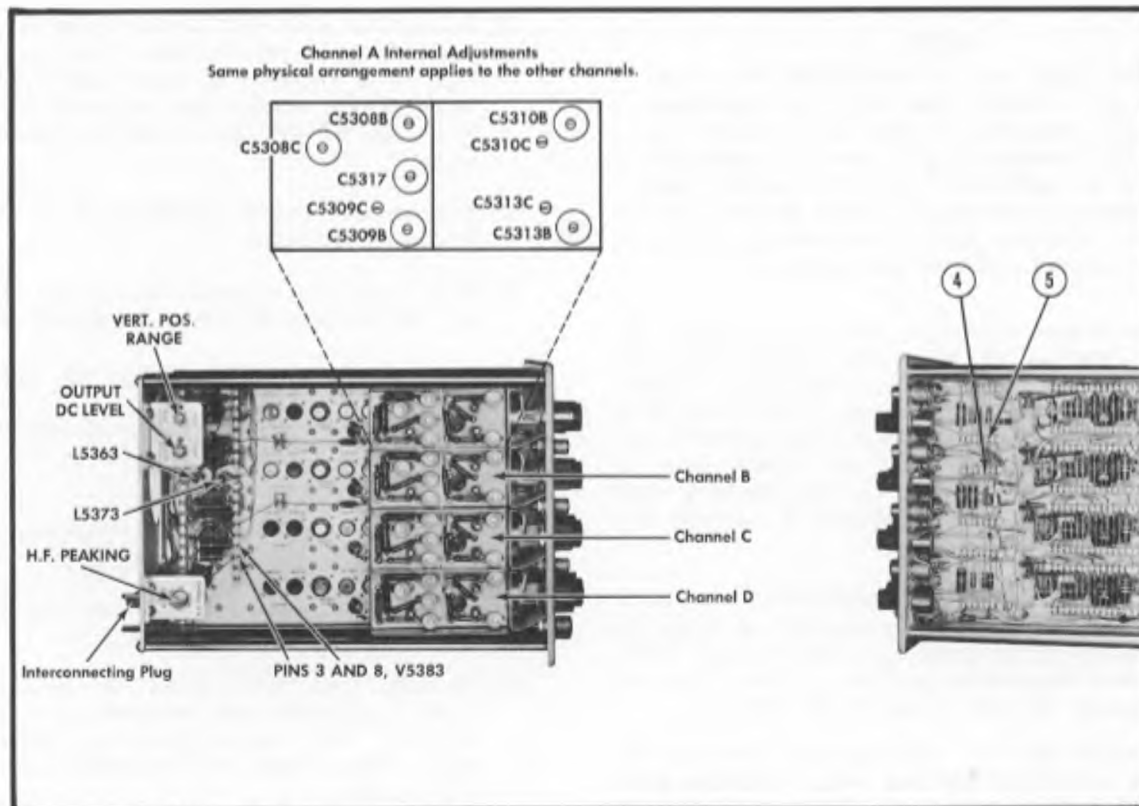

Fig. 5-1. Left-side view and right-front portion of the M Unit showing the location of the interconnecting plug, internal adjustments and test points.

**TABLE 5-1**  
**Nominal Resistances at Interconnecting Plug**

Pin Number	Polarity of Meter Lead Connected to Ground	Resistance to Ground	Remarks
1	+ or — + or —	9.4 k 11.3 k	H.F. PEAKING control*-ccw H.F. PEAKING control*-cw
2		0	Connected to ground.
3	+ or — + or —	9.4 k 11.3 k	H.F. PEAKING control*-ccw H.F. PEAKING control*-cw
4			No Connection
5			No Connection
6			No Connection
7			No Connection
8	+ or —	Infinite	ALTERNATE/CHOPPED switch- CHOPPED
	+ or —	0	ALTERNATE/CHOPPED switch- ALTERNATE
9	—	4.1 k	
	+	3.5 k	
10	—	1.7 k	
	+	2 k	
11	+ or —	72 k	
12			No Connection
13			No Connection
14			No Connection
15	—	220 Ω	
	+	130 Ω	
16	+ or —	64 k	

\*To keep from adjusting this control unnecessarily, a resistance reading between 9.4 k and 11.3 k is normal.

Stability Fully clockwise  
Horizontal Position Midrange

Preset the M-Unit front-panel controls (all channels) as follows:

VOLTS/CM .02  
MODE OFF  
VAR. GAIN CALIB.  
POSITION Midrange  
ALTERNATE/CHOPPED ALTERNATE

Remove the left-side cover from the oscilloscope. After the 15-minute warm-up period proceed with the calibration.

### CALIBRATION PROCEDURE

#### 1. Check +13.6-volt (+12.6-volt—S/N 101-3479) and +6.3-volt Supplies.

This step checks Zeners D5390 and D5391 for proper output voltages. Connect the VOM between test point 4 and ground. The meter reading should be +13.6 volts, ±2% (+12.6 volts, ±5%). Connect the VOM between test point 5 and ground. The reading should be +6.3 volts, ±5%. Disconnect the VOM.

#### 2. DC Balance (All Channels)

Set the channel A MODE switch to AC NORM. Position the trace near the center graticule line with the channel A POSITION control. Adjust the oscilloscope Focus, Intensity and Astigmatism controls for a well-defined trace of suitable intensity; adjust the Scale Illum. control for a pleasing level. Rotate the VAR. GAIN control back and forth over its range. If the trace remains stationary, as the VAR. GAIN control is rotated, no adjustment of the DC BAL. control is necessary. If the trace shifts vertically as the VAR. GAIN control is rotated, adjust the DC BAL. control (located on the front panel) until the trace remains stationary. Return the VAR. GAIN to the CALIB. position.

Repeat this procedure for the other channels. To make each succeeding channel DC Balance adjustment easier, position the trace of the previous channel out of the way with the appropriate POSITION control.

#### 3. Vertical Position Range

Set all MODE switches to OFF. Using a 3" jumper lead with test prods on each end, short together pins 3 and 8 of V5383. Note the exact position of the trace; this is the vertical system electrical center of the oscilloscope.

Remove the jumper lead and adjust the VERT. POS. RANGE control so the trace coincides with the electrical-center location noted previously.

## Calibration—Type M

### 4. Check Input Coupling Capacitor for Leakage (All Channels)

#### NOTE

A lower dc voltage can be used to make this check if a voltage as high as 500 volts is not applied during normal use of the plug-in unit. If a lower voltage is used when performing this check, trace displacement will be less by a direct proportion. For example, if the +100-volt regulated power supply is used as the dc source, trace displacement should be less than  $\frac{1}{5}$  of 2 centimeters or 4 mm.

Set Channel A MODE switch to AC NORM and position the trace to the center graticule line. Connect the connector adapter to the Channel A input connector and connect a long test lead to the adapter. The test lead should be about 4' long, or sufficiently long to reach a +500-volt source such as the oscilloscope +500-volt regulated power supply. Touch the test lead to +500 volts. Check the amount of shift after the trace returns to the screen. Trace displacement should be less than two centimeters from the original position. Remove the test lead from +500 volts and set the Channel A MODE switch to OFF. Disconnect the adapter with the test lead from Channel A.

Repeat this step for the other channels. Then disconnect the test lead from 500 volts and remove the adapter. Set all MODE switches to AC NORM.

### 5. Check Push-Pull Balance (All Channels)

This step checks the push-pull balance of Q5324 and Q5334 in each channel. If the beta of the transistors closely match each other, trace shift will not exceed the following limit. To make the check, adjust all POSITION controls to position the traces to the vertical-system electrical center. Then set each MODE switch to AC INV. and note the amount of trace shift.

Each trace should not shift more than three centimeters from the original position. Since the test oscilloscope has a vertical scan of 4 centimeters or  $\pm 2$  centimeters and the trace shift limit is  $\pm 3$  centimeters from vertical-system electrical center, it is possible for the trace to move out of visibility but still be within the trace-shift limit. Note the degree of rotation of the POSITION control required to position the trace back to the original position and compare this with a known degree of rotation required to move the trace three centimeters. Typical rotation distance is  $50^\circ$ .

### 6. Check Output DC Level

Set all MODE switches to AC NORM. and position all traces to the vertical-system electrical center. Measure the voltage between pin 3 of V5383 and ground, and between pin 8 of V5383 and ground. These voltages should measure between 65 and 70 volts and the readings should be within a fraction of a volt of each other. Readings within these limits indicate proper input dc levels to the oscilloscope vertical amplifier.

Disconnect the VOM.

### 7. Check for Excessive Grid Current (All Channels)

This step checks the Input Cathode Follower V5323 of each channel for excessive grid current, under no-signal conditions.

To make the check use three short patch cords (6" long) to connect the four inputs together, and use a fourth patch cord to ground the inputs. Set the channel A MODE switch to DC NORM. and the VOLTS/CM switch to .02. Observe the vertical shift of the trace. The trace should not shift more than two millimeters. Repeat the procedure for channels B, C, and D. If the trace for any channel shift more than two millimeters, replace V5323 and repeat steps 2, 3, 5, 6 and 7.

### 8. Check for Microphonics (All Channels)

This step checks for excessive microphonics in V5323.

To check for ringing type of microphonics, start with channel A by setting its MODE switch to AC NORM. and set the MODE switches for the other channels to OFF. Set the oscilloscope Time/Cm switch to 1 Millisec and tap lightly on the front panel of the M Unit. Microphonics should not exceed one centimeter. Set the channel A MODE switch to OFF and check the remaining channels in the same manner.

### 9. Check ALTERNATE Operation

This check tests the Four Channel Switching Circuit for proper alternate-mode of operation.

Set all MODE switches to AC NORM. and position the traces about one centimeter apart with the POSITION controls. Check that each time the sweep is triggered, the trace runs sequentially from channel A through D with various settings of the oscilloscope Time/Cm switch. After completing this step, disconnect all patch cords.

### 10. Check CHOPPED Operation

The first part of this step checks the Switching B.O. (Q6350) for proper free-running operation. The second part checks the diode gates for proper match and turn off.

(a) Check the Switching B.O. by setting the oscilloscope Time/Cm switch to  $1\ \mu\text{SEC}$  and the M-Unit ALTERNATE/CHOPPED switch to CHOPPED. Check the waveform for approximately a 250-kc chopping rate. (Waveform appears similar to the one shown in Fig. 2-2 when the traces are positioned the same distance apart.)

(b) Check the gating diodes by setting the oscilloscope Time/Cm switch to 1 Millisec. Check the width of all traces at normal intensity. The trace width should not exceed 1.5 millimeters. If a trace is wider than 1.5 millimeters, check the reverse resistances of diode pairs (D5345 and D5347, and D5346 and D5348). The resistance readings for each pair should be approximately the same to obtain proper dc-level match and minimum trace width.

### 11. Gain Adjustment (All Channels)

Set the ALTERNATE/CHOPPED switch to the ALTERNATE position and all MODE switches to DC NORM. Make sure all VAR. GAIN controls are set to CALIB. Set the oscilloscope Time/Cm switch to .5 Millisec and the triggering Mode switch to Auto. Apply a 20-millivolt signal from the oscilloscope Amplitude Calibrator to the channel A input connector. Set the channel A GAIN ADJ. to obtain exactly one centimeter of deflection.

Repeat the procedure for each of the other channels. After completing the adjustment for channel D, leave the signal connected to that channel.

**12. Check Variable Gain Control (All Channels)**

This step checks the operation of the VAR. GAIN control for each channel.

Increase the signal amplitude of the oscilloscope Amplitude Calibrator to 50 millivolts. Then rotate the channel D VAR. GAIN control to minimum gain (clockwise to a point just past the CALIB. detent position). The amplitude of the waveform should be less than one centimeter. This indicates that the ratio of the control is at least 2.5 to 1. Rotate the control through its range to check for smooth electrical operation. After completing the check, set the VAR. GAIN control to the CALIB. position.

Check the other channels by the same procedure, doing channel A last.

**13. Check AC-DC Operation of MODE switch (All Channels)**

Rotate the channel A POSITION control to position the bottom of the calibrator waveform at the center graticule line. Set the A MODE switch to AC NORM. and observe that the waveform should be close to being centered about the center graticule line. The shifting of the waveform indicates that the DC-AC NORM. positions of the MODE switch and the input coupling capacitor function properly.

To check the DC-AC INV. positions of the MODE switch, set the MODE switch to DC INV. Rotate the channel A POSITION control to position the top of the calibrator waveform at the center graticule line. Set the MODE switch to AC INV. and observe that the waveform shifts up to its average voltage level.

Repeat the procedure for the other channels, doing channel D last.

**14. Check VOLTS/CM Switch Attenuation Ratios (All Channels)**

With the signal applied to the channel D input connector, set the MODE switch to DC NORM. Use the POSITION control to align the waveform with the graticule lines and check for proper vertical deflection at each position of the VOLTS/CM switch. Use the information in Table 5-2 as a convenient guide. Amplitude tolerance for each setting should be within 6%. (VOLTS/CM attenuators and calibrator tolerance are each 3%. The tolerance of the precision calibrator used at the factory to check M-Unit attenuators is  $\pm 1/4\%$ .)

Repeat the procedure for the other channels with the calibrator signal applied to the appropriate channel. After checking the VOLTS/CM switch for all channels, disconnect the calibrator signal.

**15. Input-Capacitance Standardization and Attenuator Compensation (All Channels)**

This step is a combination procedure which describes a method of adjusting the input capacitance of each channel for approximately 47 picofarads for all positions of the

**TABLE 5-2**  
**VOLTS/CM Switch Attenuation Check**

Oscilloscope Amplitude Calibrator Output	VOLTS/CM Switch Setting	Vertical Deflection in Centimeters
50 millivolts	.02	2.5
.1 volt	.05	2
.2 volt	.1	2
.5 volt	.2	2.5
1 volt	.5	2
2 volts	1	2
5 volts	2	2.5
10 volts	5	2
20 volts	10	2

VOLTS/CM switch. This permits an attenuator probe, when compensated for one setting of the VOLTS/CM switch, to be used for all settings without readjustment. In addition, this procedure describes a method for compensating the attenuators so that the ac attenuation is equal to the dc attenuation.

Turn on the Type 105 Square-Wave Generator, or equivalent. Set the generator for an output frequency of 1 kc and its output amplitude to minimum. Connect a 50-ohm termination to the Output connector on the generator. Connect the other end of the termination through a 5XT attenuator, 50-ohm cable, another 50-ohm termination and a 47-pf Input Time Constant Standardizer to the channel A input connector (see Fig. 5-2).

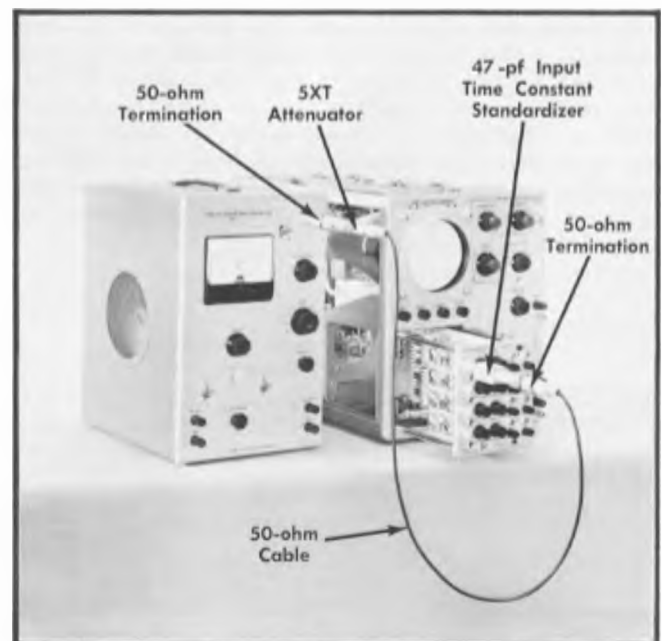

Fig. 5-2. The manner in which the Type 105 Square-Wave Generator should be connected to the M Unit to perform the first portion of step 15.

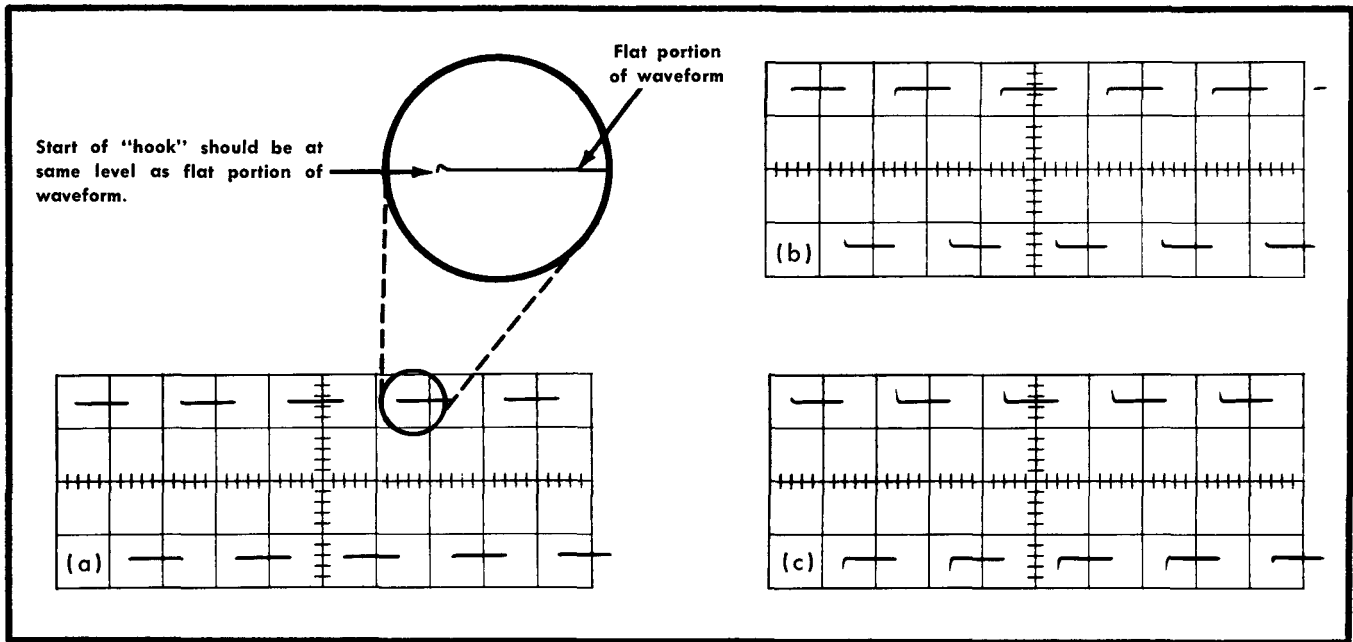

Fig. 5-3. Adjusting the input capacitance and attenuator compensation: (a) proper adjustment; (b) improper input-capacitance adjustment; (c) attenuator over compensated. Sweep rate: 0.5 millisc/cm.

Set the A VOLTS/CM switch to .02 and increase the output amplitude of the square-wave generator to produce a deflection of about 3 centimeters on the crt. Set the MODE switches for the other channels to OFF.

Table 5-3 lists the setting of the VOLTS/CM switch that connects each attenuator into the input circuit. The capacitor for each setting of the VOLTS/CM switch is listed according to the effect it has on the square wave. When adjustments are properly made, the waveform for each setting should have an optimum square corner with minimum hook and flat top, as shown in Fig. 5-3(a). (Some M Units may exhibit a small amount of hook at one or more switch positions.) The enlarged illustration of the corner of the waveform shows the appearance of hook when adjusted to minimum. Waveforms (b) and (c) in Fig. 5-3 show two types of waveform distortion that may result from improperly adjusted capacitors.

**TABLE 5-3**  
Input-Capacitance Standardization  
and Attenuator Compensation

VOLTS/CM Switch Setting	Affects Top of Square Wave	Affects Corner of Square Wave
.02	C5317	
.05	C5308B	C5308C
.1	C5309B	C5309C
.2*	C5310B	C5310C
2**	C5313B	C5313C

\* Remove 5XT attenuator.

\*\* Remove both 50-ohm terminations.

Maintain approximately 3 centimeters of vertical deflection by adjusting the Output Amplitude control on the square-wave generator each time the VOLTS/CM switch is moved from one position to the next. In the .2 VOLTS/CM switch position it will be necessary to remove the 5XT attenuator to obtain more signal drive to the M Unit. In the 2 VOLTS/CM switch position, remove both terminations and connect the cable directly from the generator to the 47-pf Input Time Constant Standardizer. To prevent a signal shock hazard, turn the DC ON-OFF switch to the OFF position on the Type 105 before removing the attenuator, terminations, or applying the signal to the other channels. After the proper connections are made, turn the Type 105 DC ON-OFF switch to ON and continue with the adjustments.

Disconnect the signal from channel A, and set the A MODE switch to OFF. Apply the signal to the other channels and repeat the procedure.

### 16. Check Square-Wave Response (All Channels)

Set the Output Amplitude control on the square-wave generator to minimum. Connect the Output connector on the Type 105 (or equivalent) through a 50-ohm termination, 5XT attenuator, 50-ohm cable, and another 50-ohm termination to the channel A input connector. (This is the same setup shown in Fig. 5-2 except that the 47-pf Input Time Constant Standardizer is not used.) Set the channel A MODE switch to DC NORM. and set the MODE switches for the other channels to OFF. Set the A VOLTS/CM switch to .02. Adjust the generator output amplitude for a vertical deflection of about 3 centimeters. Check the waveform for flat tops, at the frequencies listed in Table 5-3. The oscilloscope Time/CM switch setting to use for each frequency is listed in the table.

**TABLE 5-4**  
**Square-Wave Response Check**

Square-Wave Generator Output Frequency	Oscilloscope Time/Cm Switch Setting
100 cps	5 Millisec
250 cps	2 Millisec
1 kc	.5 Millisec
2.5 kc	.2 Millisec
10 kc	50 $\mu$ Sec

When the VOLTS/CM switch is set to each of its switch positions, maintain approximately 3 centimeters of vertical deflection by adjusting the Type 105 Amplitude control. In addition, it will be necessary to make the following setup changes as you proceed: Remove the 5XT attenuator when the VOLTS/CM switch is set to the .5 position, and remove both 50-ohm terminations when the VOLTS/CM switch is set to the 5 position. These changes are necessary to obtain sufficient signal drive as the VOLTS/CM switch is advanced toward the 10 position.

Any marked departure from a flat-topped waveform when applying a 100-cps square-wave signal could indicate a defective protective network C5318 and R5318. If C5318 is open, for example, the tops of the waveform for all positions of the VOLTS/CM switch will slope downward. If trouble is suspected, you can usually verify your findings by comparing the waveform with those obtained on the other channels.

If all the adjustments listed in the *last* column of Table 5-3 (step 15) are correct, and a 10-kc signal is applied, an optimum flat-top waveform will be displayed at each setting of the VOLTS/CM switch from .05 to 10. However, if one or more of the adjustments are not made correctly, the waveform will not have a flat top for those switch positions utilizing the maladjusted attenuator network. To compensate or touch-up an attenuator, continue to apply the 10-kc signal, set the VOLTS/CM switch to the appropriate setting listed in the first column of Table 5-3, and adjust the applicable capacitor listed in the last column. The 47-pf Input Time Constant Standardizer is not needed for this adjustment.

After completing the check for channel A, make the same check for the other channels by repeating the procedure. After completing the check for the last channel, disconnect the signal from the input connector and turn off the Type 105.

### 17. Channel A Output DC Level

In this step the channel A input connector is grounded and the dc level at the "A" SIGNAL OUT connector is adjusted to zero or ground level, using channel B as a dc voltmeter.

Match the levels by first setting the oscilloscope Time/CM switch to .5 Millisec. Set the channel A VOLTS/CM switch to .02 and the channel B VOLTS/CM switch to 2. Set the A and B MODE switches to DC NORM. Set the MODE switches for the remaining channels to OFF. Connect a short patch cord between the channel A input connector and ground. Use the A and B POSITION controls to position the traces to coincide.

Connect another short patch cord between the "A" SIGNAL OUT connector and the channel B input connector. If the channel B trace is displaced from the A trace, carefully adjust the OUTPUT DC LEVEL control until the channel B trace is moved back as accurately as possible to coincide with the A trace. Disconnect the patch cord connected between the A input connector and ground.

### 18. Check Gain of Channel A Signal Output Amplifier

Check the gain of the Channel A Signal Output Amplifier by applying a 20-millivolt signal from the oscilloscope calibrator to the channel A input connector. The channel B waveform should be at least one centimeter, peak-to-peak, in amplitude.

Disconnect the signal and the patch cords.

### 19. High-Frequency Compensation

The adjustment procedure which follows describes a method of checking and adjusting the M-Unit Output Amplifier for optimum high-frequency response.

To check the response, first turn on the Type 107 Square-Wave Generator (or equivalent). Remove the Plug-In Extension, insert the M Unit directly into the oscilloscope plug-in compartment, and tighten the Securing Rod.

Connect a 50-ohm cable directly to the Output connector on the Type 107. Connect the other end of the cable through a 50-ohm termination to the channel A input connector on the M Unit.

Set the channel B MODE switch to OFF and set the oscilloscope Time/Cm switch to .1  $\mu$ Sec. Set the Approximate Frequency control on the Type 107 for an output of approximately 450 kc, and adjust the Approximate Amplitude control for a vertical deflection of three centimeters.

If the high-frequency compensating circuits in the M Unit are in proper adjustment, the leading corner of the waveform should be square without appreciable overshoot or ringing, similar to the display shown in Fig. 5-4(a). However, if there is any rolloff at the corner, shown accentuated in Fig. 5-4(c), or overshoot (with or without ringing) as shown in Fig. 5-4(d), the high-frequency compensating circuits are in need of adjustment.

If adjustment is required, rotate the H.F. PEAKING control fully clockwise. Adjust the slugs in L5363 and L5373 in equal increments for a square-cornered waveshape, similar to Fig. 5-4(b). Then adjust the H.F. PEAKING control slowly counterclockwise to obtain an optimum square leading corner, as shown in Fig. 5-4(a).

Set the VOLTS/CM switch for the other channels to .02, and repeat the procedure for each channel. When checking each channel, set the appropriate MODE switch to DC NORM. and set the other MODE switches to OFF. If one or more channels show waveforms which do not have an optimum square corner, readjust L5363, L5373 and the H.F. PEAKING control slightly to obtain the best compromise.

### 20. Check Risetime (All Channels)

A risetime measurement of each channel will check the accuracy of the adjustments made in steps 15 and 19. Make

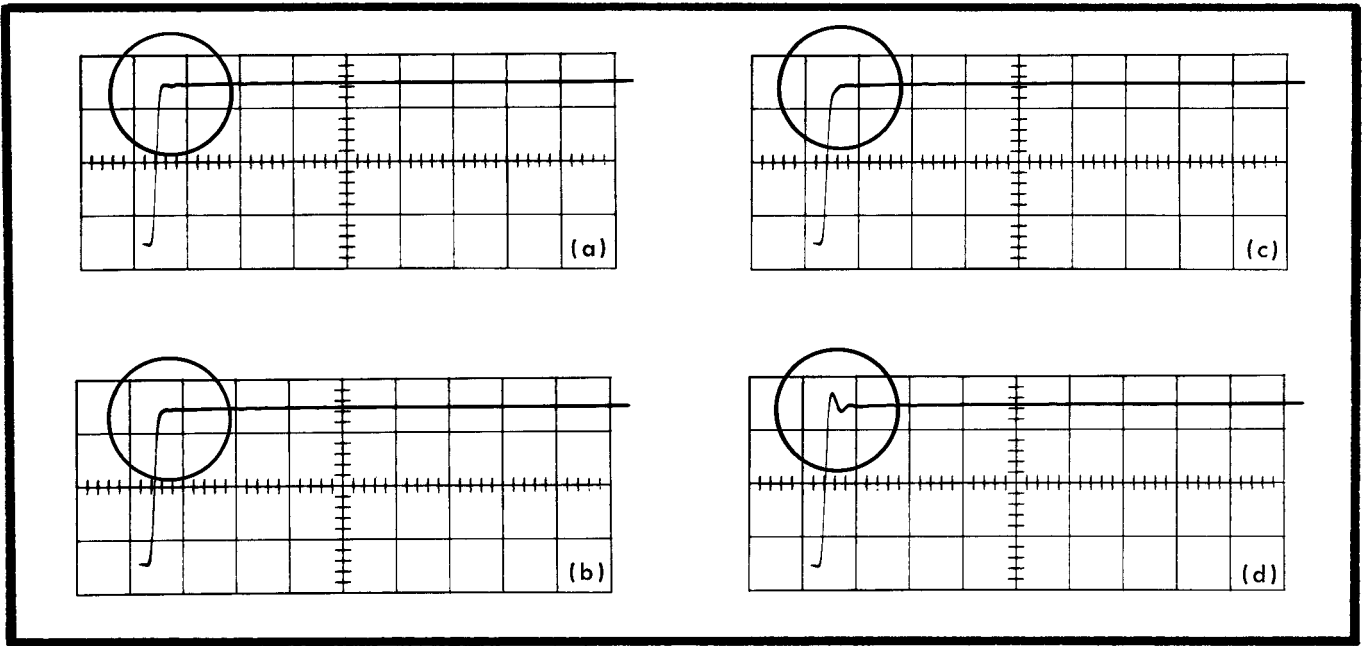

Fig. 5-4. Checking the high-frequency compensation of the M Unit. Sweep rate:  $0.1 \mu\text{sec/cm}$ . (a) Peaking circuits properly adjusted. (b) L5363 and L5373 properly adjusted—H.F. PEAKING control rotated fully clockwise. (c) Rolloff and (d) overshoot, caused by maladjusted peaking circuits.

the measurement with the same setup used in step 19. Leave the signal applied to the channel D input connector. Decrease the signal amplitude from the Type 107 with the Approximate Amplitude and, if necessary, the A VAR. GAIN control, until a deflection of exactly two centimeters is obtained. Set the oscilloscope Horizontal Display switch to 5X Mag. The sweep rate is now  $20 \text{ nsec/cm}$ . Use the M-Unit POSITION and the oscilloscope Horizontal Position controls to position the waveform for making the measurement (see Fig. 5-5). Measure the time interval between the 10% and 90% amplitude levels of the rising portion of the waveform. The time interval should not exceed 17 nanoseconds ( $17 \times 10^{-9}$  seconds).

Repeat this step for each of the other channels. When checking each channel individually, set the appropriate MODE switch to DC NORM. and the others to OFF.

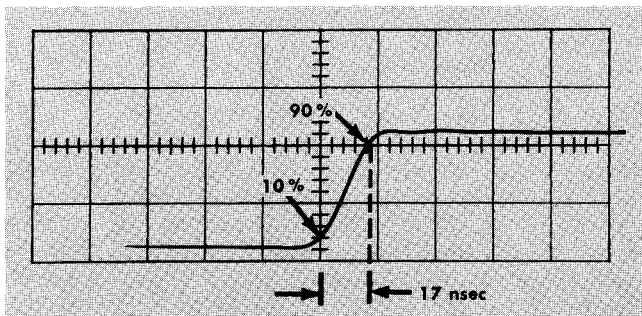

Fig. 5-5. Measurement of vertical risetime for each channel. Sweep rate:  $20 \text{ nsec/cm}$ .

## 21. Check Risetime of the Channel A Signal Output Amplifier

To check the risetime of the channel A Signal Output Amplifier, leave the signal applied to channel A. Connect the cable-connector end of a 10X properly-compensated attenuator probe to the channel B input connector. Plug the probe tip (with a banana plug attached to its tip) into the "A" SIGNAL OUT connector. Set the B MODE switch to DC NORM. and set the B VOLTS/CM switch to .2.

Rotate the Type 107 Approximate Frequency control fully counterclockwise ( $0.4 \text{ mc}$ ). Set the oscilloscope Triggering Mode switch to AC LF Reject, the Time/Cm switch to  $.5 \mu\text{Sec}$ , and the Horizontal Display switch to Normal. Use the oscilloscope Horizontal Position control to center the

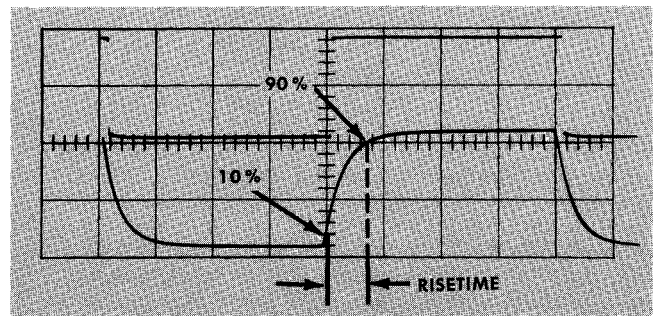

Fig. 5-6. Measuring the risetime of the Channel A Signal Output Amplifier. Sweep rate:  $0.5 \mu\text{sec/cm}$ .



display on the screen. Adjust the oscilloscope Triggering Level and Stability controls to obtain a stable A and B waveform display. Position the waveforms, using the A and B POSITION controls and the oscilloscope Horizontal Position control, to the points shown in Fig. 5-6. Use the Type 107 Approximate Amplitude control and, if necessary, the channel A VAR. GAIN control, to obtain exactly

two centimeters of deflection for the channel B waveform. Measure the time interval between the 10% and 90% amplitude levels on the rising portion of the squarewave. It should not exceed 0.35 microsecond.

If the risetime is within the above specifications, disconnect the signal and the 10X attenuator probe. Turn off the Type 107.



# SECTION 6

## PARTS LIST AND DIAGRAMS

### PARTS ORDERING INFORMATION

Replacement parts are available from or through your local Tektronix Field Office.

Changes to Tektronix instruments are sometimes made to accommodate improved components as they become available, and to give you the benefit of the latest circuit improvements developed in our engineering department. It is therefore important, when ordering parts, to include the following information in your order: Part number including any suffix, instrument type, serial number, and modification number if applicable.

If a part you have ordered has been replaced with a new or improved part, your local Tektronix Field Office will contact you concerning any change in part number.

### ABBREVIATIONS AND SYMBOLS

a or amp	amperes	mm	millimeter
BHS	binding head steel	meg or M	megohms or mega (10 <sup>6</sup> )
C	carbon	met.	metal
cer	ceramic	$\mu$	micro, or 10 <sup>-6</sup>
cm	centimeter	n	nano, or 10 <sup>-9</sup>
comp	composition	$\Omega$	ohm
cps	cycles per second	OD	outside diameter
crt	cathode-ray tube	OHS	oval head steel
CSK	counter sunk	p	pico, or 10 <sup>-12</sup>
dia	diameter	PHS	pan head steel
div	division	piv	peak inverse voltage
EMC	electrolytic, metal cased	plstc	plastic
EMT	electrolytic, metal tubular	PMC	paper, metal cased
ext	external	poly	polystyrene
f	farad	Prec	precision
F & I	focus and intensity	PT	paper tubular
FHS	flat head steel	PTM	paper or plastic, tubular, molded
Fil HS	fillister head steel	RHS	round head steel
g or G	giga, or 10 <sup>9</sup>	rms	root mean square
Ge	germanium	sec	second
GMV	guaranteed minimum value	Si	silicon
h	henry	S/N	serial number
hex	hexagonal	t or T	tera, or 10 <sup>12</sup>
HHS	hex head steel	TD	toroid
HSS	hex socket steel	THS	truss head steel
HV	high voltage	tub.	tubular
ID	inside diameter	v or V	volt
incd	incandescent	Var	variable
int	internal	w	watt
k or K	kilohms or kilo (10 <sup>3</sup> )	w/	with
kc	kilocycle	w/o	without
m	milli, or 10 <sup>-3</sup>	WW	wire-wound
mc	megacycle		

### SPECIAL NOTES AND SYMBOLS

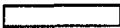
X000	Part first added at this serial number.
000X	Part removed after this serial number.
*000-000	Asterisk preceding Tektronix Part Number indicates manufactured by or for Tektronix, or reworked or checked components.
Use 000-000	Part number indicated is direct replacement.
	Internal screwdriver adjustment.
	Front-panel adjustment or connector.

FRONT

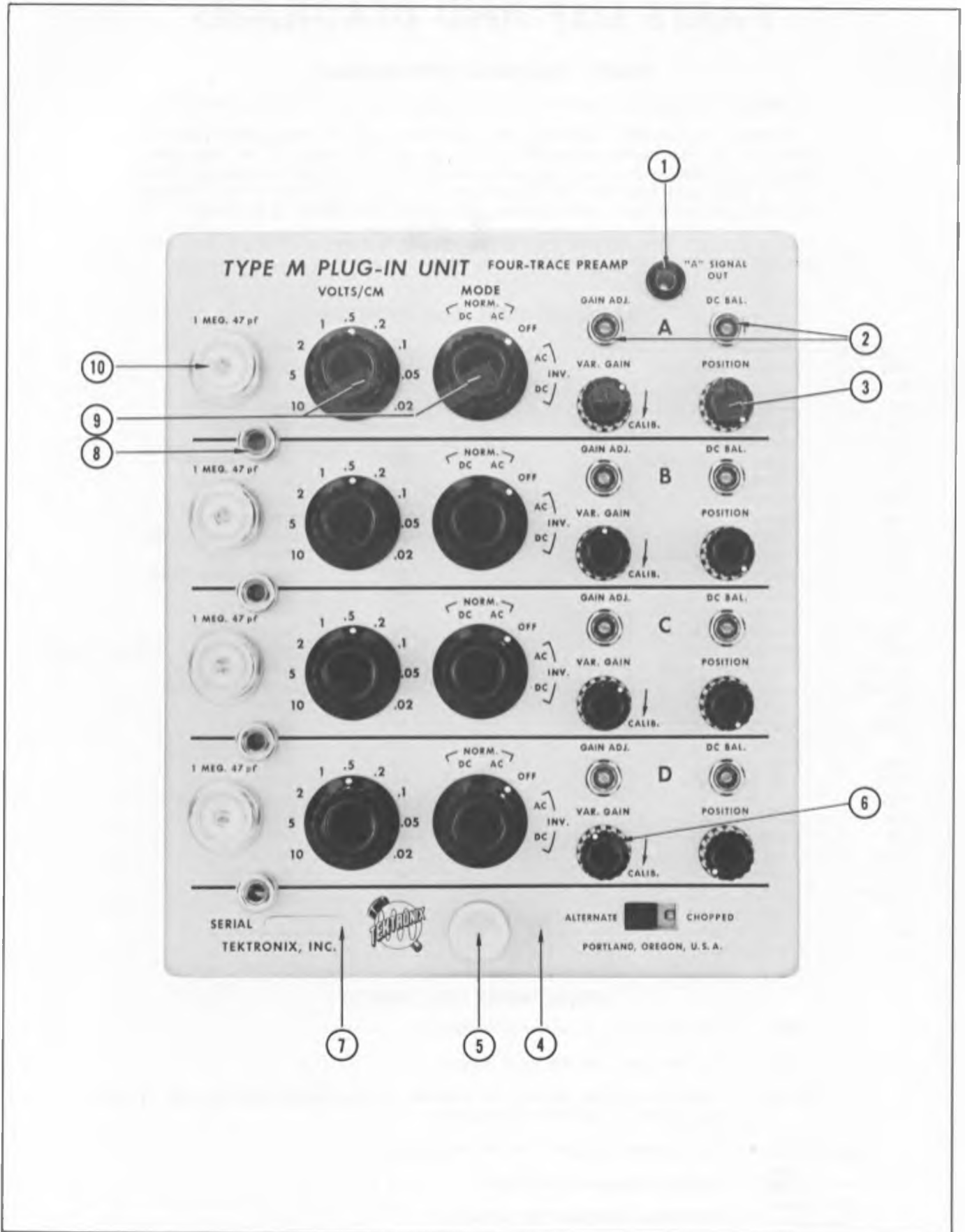

## FRONT

REF. NO.	PART NO.	SERIAL/MODEL NO.		QTY.	DESCRIPTION
		EFF.	DISC.		
1	136-0106-00	101	628	1	SOCKET, banana jack, black
	136-0138-00	629	6329	1	SOCKET, banana jack, black
	136-0140-00	6330		1	SOCKET, banana jack, charcoal
	210-0895-00			1	WASHER, insulating
	210-0465-00			2	NUT, hex, $\frac{1}{4}$ -32 x $\frac{3}{8}$ x $\frac{3}{32}$ inch
2	210-0223-00			1	LUG, solder, $\frac{1}{4}$ inch hole, lock
	358-0075-00			8	BUSHING, $\frac{1}{4}$ -32 x .343 OD x .295 inch long, pot mounting
3	210-0223-00	101	6339X	1	LUG, solder, $\frac{1}{4}$ inch hole, lock
	366-0085-00	101	6329	4	KNOB, small black—POSITION
4	366-0153-00	6330		4	KNOB, small charcoal—POSITION
	210-0905-00			4	WASHER, flat, #14
	210-0223-00			4	LUG, solder, $\frac{1}{4}$ inch hole, lock
5	333-0679-00			1	PANEL, front
	387-0465-00	101	669	1	PLATE, sub panel, front
	387-0644-00	670		1	PLATE, sub panel, front
6	366-0125-00			1	KNOB, plug-in securing
	210-0894-00			1	WASHER, polyethylene, .190 ID x $\frac{7}{16}$ OD x $\frac{1}{32}$ inch
7	366-0085-00	101	4129	4	KNOB, small black—VAR. GAIN
	366-0189-00	4130		4	KNOB, small red—VAR. GAIN
8	334-0679-00			1	TAG, serial number insert
	129-0035-00			4	POST, ground, assembly
	- - - - -			-	Consisting Of:
	355-0507-00			1	STEM, binding post
	200-0103-00			1	CAP, binding post
	210-0455-00			1	NUT, hex, $\frac{1}{4}$ -28 x $\frac{3}{8}$ x $\frac{3}{32}$ inch
	210-0011-00			1	LOCKWASHER, internal, $\frac{1}{4}$ inch
	366-0136-00	101	6329	8	KNOB, small black—VOLTS/CM & MODE
	366-0173-00	6330		8	KNOB, small charcoal—VOLTS/CM & MODE
	210-0413-00			4	NUT, hex, $\frac{3}{8}$ -32 x $\frac{1}{2}$ inch
	358-0029-00			4	BUSHING, hex, panel
	9	210-0840-00			8
210-0013-00				4	LOCKWASHER, internal, $\frac{3}{8}$ x $\frac{11}{16}$ inch
210-0494-00				4	NUT, hex, $\frac{3}{8}$ -32 x $\frac{1}{2}$ x $\frac{11}{16}$ inch
210-0012-00				4	LOCKWASHER, pot, internal, $\frac{3}{8}$ x $\frac{1}{2}$ inch
131-0081-00		101	3119	4	CONNECTOR, chassis mount, coax., 1 contact, female, UHF
131-0126-00		3120		4	CONNECTOR, chassis mount, coax., 1 contact, BNC

RIGHT SIDE

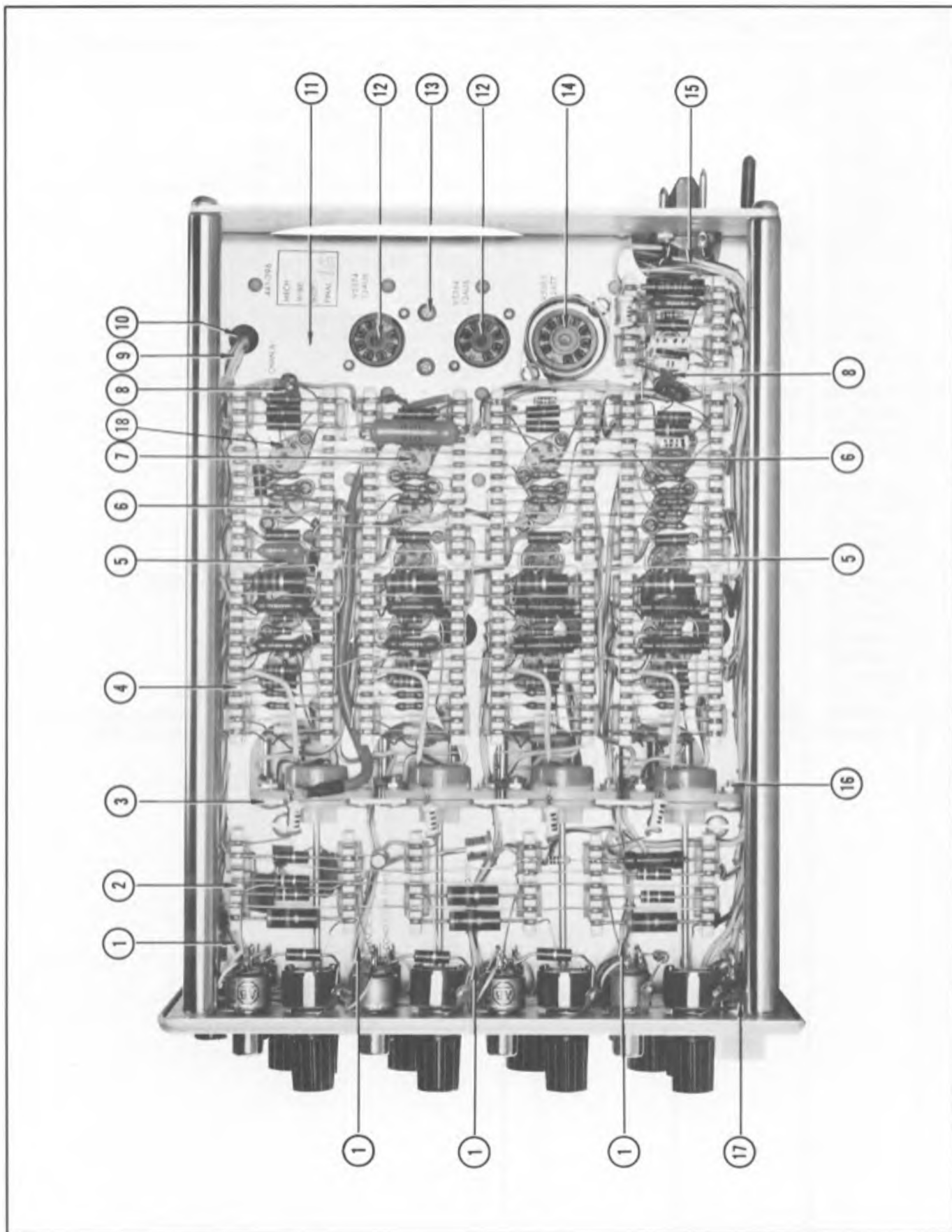

## RIGHT SIDE

REF. NO.	PART NO.	SERIAL/MODEL NO.		QTY.	DESCRIPTION
		EFF.	DISC.		
1	179-0566-00			4	CABLE, harness, pot
2	124-0149-00			8	STRIP, ceramic, 7 notches x 1 <sup>5</sup> / <sub>32</sub> x 7 <sup>1</sup> / <sub>16</sub> inch
	361-0009-00			16	SPACER, nylon, molded
3	406-0731-00			1	BRACKET, pot gain adjust
	211-0504-00			2	SCREW, 6-32 x 1 <sup>1</sup> / <sub>4</sub> inch BHS
	210-0202-00			1	LUG, solder, SE6, with 2 wire holes
4	124-0147-00			16	STRIP, ceramic, 13 notches x 2 x 7 <sup>1</sup> / <sub>16</sub> inch
	361-0009-00			32	SPACER, nylon, molded
5	136-0101-00			4	SOCKET, 5 pin
	213-0055-00	101	3409	8	SCREW, thread cutting, 2-56 x 3 <sup>3</sup> / <sub>16</sub> inch PHS, phillips
	213-0120-00	3410		8	SCREW, thread forming 2-56 x 1 <sup>1</sup> / <sub>4</sub> inch, PHS, phillips
	210-0215-00			5	LUG, banana, pee wee
6	136-0095-00	101	5269	14	SOCKET, 4 pin, transistor
	136-0181-00	5270		14	SOCKET, 3 pin transistor
	213-0113-00	101	5269	28	SCREW, thread forming, 2-32 x 5 <sup>1</sup> / <sub>16</sub> inch RHS, phillips
	354-0234-00	5270		14	RING, locking, transistor socket
7	136-0095-00	101	2759	1	SOCKET, 4 pin, transistor
	213-0113-00	101	2759	2	SCREW, thread forming, 2-32 x 5 <sup>1</sup> / <sub>16</sub> inch RHS, phillips
	136-0078-00	2760		1	SOCKET, sub miniature
	211-0001-00	2760	3409	2	SCREW, 2-56 x 1 <sup>1</sup> / <sub>4</sub> inch RHS
	210-0001-00	2760	3409	2	LOCKWASHER, internal, #2
	210-0405-00	2760	3409	2	NUT, hex, 2-56 x 3 <sup>3</sup> / <sub>16</sub> inch
	213-0120-00	3410		2	SCREW, thread forming, 2-56 x 1 <sup>1</sup> / <sub>4</sub> inch PHS, phillips
8	210-0201-00			2	LUG, solder, SE4
	213-0044-00			2	SCREW, thread cutting, 5-32 x 3 <sup>3</sup> / <sub>16</sub> inch PHS, phillips
9	179-0567-00	101	2759	1	CABLE, harness, channel A
	179-0725-00	2760		1	CABLE, harness, channel A
10	348-0002-00			1	GROMMET, rubber, 1 <sup>1</sup> / <sub>4</sub> inch
11	441-0396-00	100	3409	1	CHASSIS
	441-0510-00	3410		1	CHASSIS
	210-0457-00	X670		3	NUT, keps, 6-32 x 5 <sup>1</sup> / <sub>16</sub> inch
	211-0504-00			2	SCREW, 6-32 x 1 <sup>1</sup> / <sub>4</sub> inch BHS
	211-0507-00			1	SCREW, 6-32 x 5 <sup>1</sup> / <sub>16</sub> inch BHS
	210-0006-00			1	LOCKWASHER, internal, # 6
	210-0407-00			1	NUT, hex, 6-32 x 1 <sup>1</sup> / <sub>4</sub> inch
12	136-0008-00			2	SOCKET, STM7G
	213-0044-00			4	SCREW, thread cutting, 5-32 x 3 <sup>3</sup> / <sub>16</sub> inch PHS, phillips
13	213-0035-00			2	SCREW, thread cutting, 4-40 x 1 <sup>1</sup> / <sub>4</sub> inch PHS, phillips
14	136-0015-00			1	SOCKET, STM9G
	337-0005-00	X825		1	SHIELD, sockket
	213-0044-00	101	824	2	SCREW, thread cutting, 5-32 x 3 <sup>3</sup> / <sub>16</sub> inch PHS, phillips
	211-0033-00	825		2	SCREW, fastening, 8-32 x 1 <sup>1</sup> / <sub>2</sub> inch
	210-0004-00	825		4	LOCKWASHER, internal, #4
	210-0406-00	825		2	NUT, hex, 4-40 x 3 <sup>3</sup> / <sub>16</sub> inch
15	179-0571-00	101	824	1	CABLE, harness, channel D
	179-0682-00	825		1	CABLE, harness, channel D
16	211-0011-00			8	SCREW, 4-40 x 3 <sup>3</sup> / <sub>16</sub> inch
	210-0004-00			8	LOCKWASHER, internal, #4
	210-0406-00			8	NUT, hex, 4-40 x 3 <sup>3</sup> / <sub>16</sub> inch
17	210-0406-00			2	NUT, hex, 4-40 x 3 <sup>3</sup> / <sub>16</sub> inch
18	136-0095-00	101	5269	1	SOCKET, 4 pin transistor
	136-0182-00	5270		1	SOCKET, 4 pin transistor
	213-0113-00	101	5269	2	SCREW, thread forming, 2-32 x 5 <sup>1</sup> / <sub>16</sub> inch RHS phillips
	354-0234-00	5270		1	RING, locking, transistor socket

LEFT SIDE

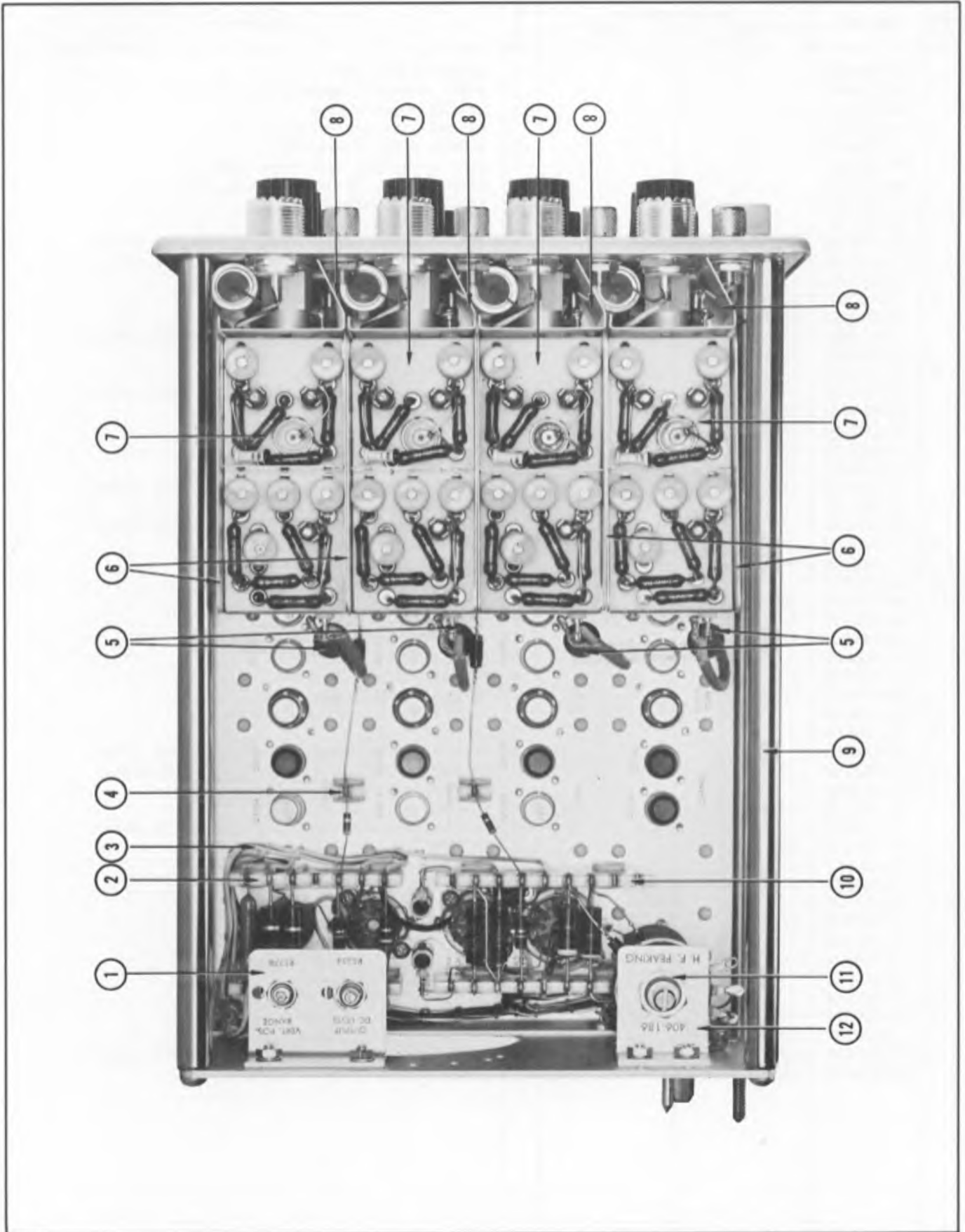



## LEFT SIDE

REF. NO.	PART NO.	SERIAL/MODEL NO.		QTY.	DESCRIPTION
		EFF.	DISC.		
1	406-0726-00			1	BRACKET, pot
	211-0507-00			2	SCREW, 10-32 x 3/8 inch BHS
	210-0006-00			2	LOCKWASHER, internal, #6
	210-0407-00			2	NUT, hex, 6-32 x 1/4 inch
2	124-0089-00			2	STRIP, ceramic, 3/4 inch x 7 notches, clip mounted
	361-0009-00			4	SPACER, nylon, molded
3	179-0568-00	101	2759	1	CABLE, harness, output
	179-0726-00	2760		1	CABLE, harness, output
4	124-0118-00			2	STRIP, ceramic, 7/16 inch x 1 notch, clip mounted
	361-0009-00			2	SPACER, nylon, molded
5	348-0003-00			4	GROMMET, rubber, 5/16 inch
6	337-0467-00			4	SHIELD, attenuator switch
	210-0002-00	X3270		3	LOCKWASHER, external, #2
	210-0001-00	X3270		9	LOCKWASHER, internal, #2
	211-0001-00	X3270		3	SCREW, 2-56 x 1/4 inch RHS phillips
	211-0022-00	X3270		2	SCREW, 2-56 x 3/16 inch RHS phillips
	210-0405-00	X3270		5	NUT, hex, 2-56 x 3/16 inch
	210-0259-00	X3270		1	LUG, solder, #2
7	262-0435-00			4	SWITCH, wired, vertical
	- - - - -			-	Includes:
	406-0728-00			1	BRACKET, attenuator switch assembly
	211-0023-00			1	SCREW, 4-40 x 1/4 inch FHS
	210-000100			1	LOCKWASHER, internal, #2
	210-0215-00			1	LUG, banana, pee wee
	337-0465-00			1	SHIELD, attenuator switch
	131-0182-00			1	CONNECTOR, terminal feed thru
	358-0135-00			2	BUSHING, teflon
8	337-0468-00			4	SHIELD, attenuator switch
9	384-0508-00	101	4999	4	ROD, frame, round, 3/8 x 8 7/8 inch
	384-0631-00	5000		4	ROD, frame, round, 3/8 x 8 7/8 inch
	212-0044-00			4	SCREW, 8-32 x 1/2 inch RHS, phillips
10	124-0090-00			2	STRIP, ceramic, 3/4 inch x 9 notches, clip mounted
	361-0009-00			4	SPACER, nylon, molded
11	210-0413-00			1	NUT, hex, 3/8-32 x 1/2 inch
	210-0840-00			1	WASHER, .390 ID x 9/16 OD x .020 inch
	210-0012-00			1	LOCKWASHER, pot, internal, 3/8 x 1/2 inch
12	406-0186-00			1	BRACKET, pot, HF peaking
	211-0507-00			2	SCREW, 6-32 x 5/16 inch BHS
	210-0006-00			2	LOCKWASHER, internal, #6
	210-0407-00			2	NUT, hex, 6-32 x 1/4 inch

REAR

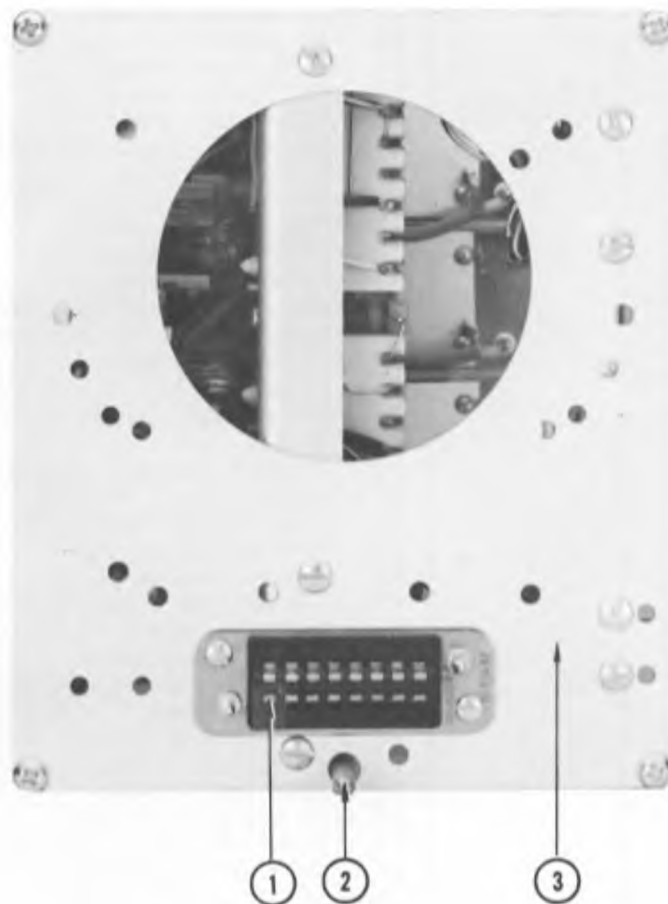

REF NO	PART NO	SERIAL/MODEL NO		QTY	DESCRIPTION
		EFF.	DISC		
1	131-0017-00			1	CONNECTOR, chassis mounted, 16 contact, male
	211-0008-00			2	SCREW, 4-40 x 1/4 inch BHS
	210-0004-00			1	LOCKWASHER, internal, #4
	210-0201-00			1	LUG, solder, SE4
	210-0406-00			2	NUT, hex, 4-40 x 3/16 inch
2	384-0510-00			1	ROD, plug-in securing
	-----			-	rod includes:
3	354-0025-00			1	RING, retaining, #18 securing
	387-0529-00			1	PLATE, back

STANDARD ACCESSORIES

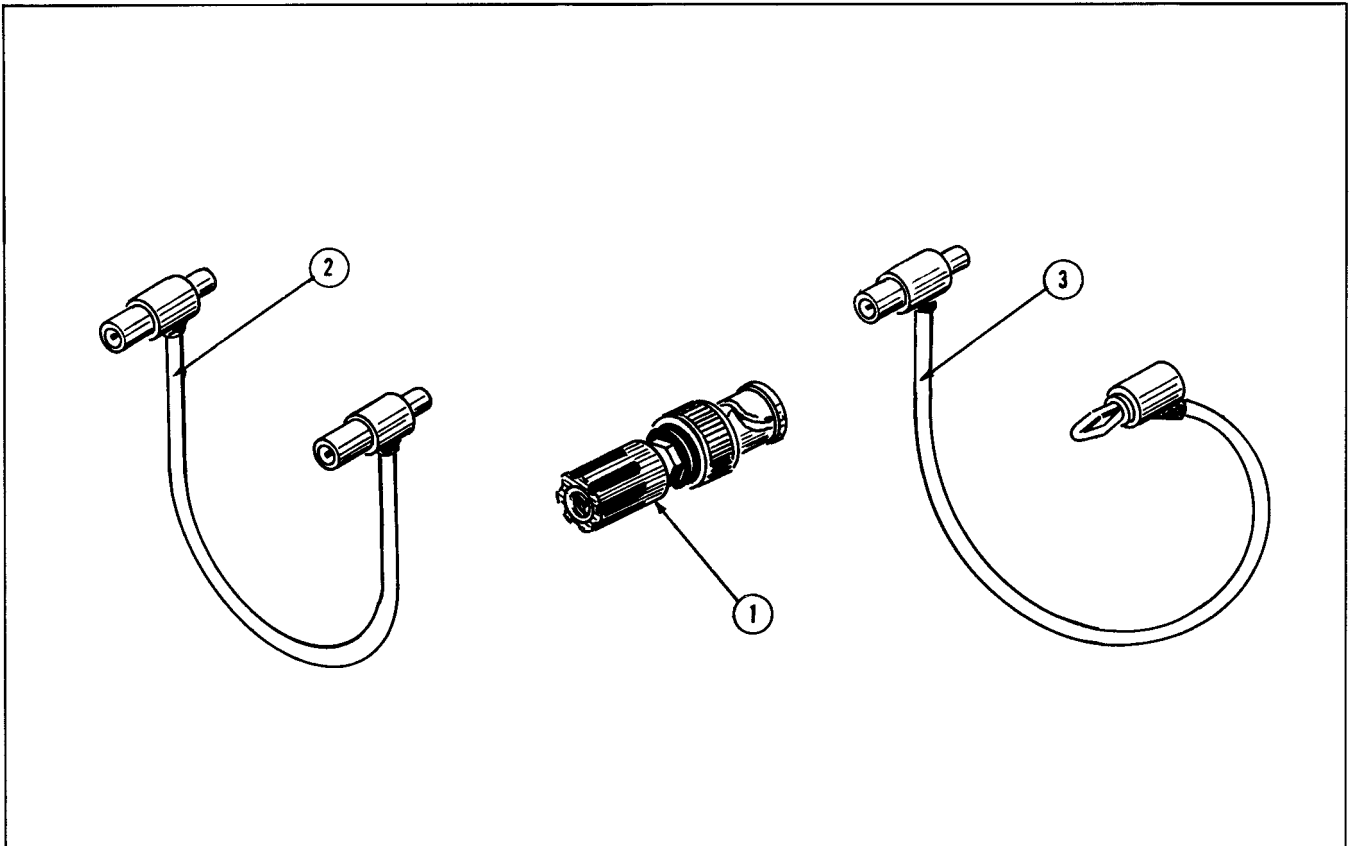

REF. NO.	PART NO.	SERIAL/MODEL NO.		QTY.	DESCRIPTION
		EFF.	DISC.		
1	103-0033-00	X3120		4	ADAPTER, BNC to binding post
2	012-0031-00	101	5598	1	CORD, patch
	012-0087-00	5599		1	CORD, patch
3	012-0091-00	X5599		1	CORD, patch
--	070-0295-00			2	MANUAL, instruction (not shown)



# PARTS LIST

Values are fixed unless marked Variable.

Ckt. No.	Tektronix Part Number	Description	S/N Range
<b>Bulbs</b>			
B5323A,B,C,D	150-0035-00	Neon A1D	X5970-up
<b>Capacitors</b>			
Tolerance $\pm 20\%$ unless otherwise indicated.			
Tolerance of all electrolytic capacitors are as follows: (with exceptions)			
3V — 50V = $-10\%$ , $+250\%$			
51V — 350V = $-10\%$ , $+100\%$			
351V — 450V = $-10\%$ , $+50\%$			
C5301A,B,C,D	Use *285-0672-00	.1 $\mu\text{f}$	PTM 600 v
C5304 A,B,C,D	281-576	11 $\mu\text{mf}$	Cer. 500 v
C5308A A,B,C,D	281-500	2.2 $\mu\text{mf}$	Cer. 500 v
C5308B A,B,C,D	281-060	2-8 $\mu\text{mf}$	Cer. Var.
C5308C A,B,C,D	281-061	5.5-18 $\mu\text{mf}$	Cer. Var.
C5309B A,B,C,D	281-061	5.5-18 $\mu\text{mf}$	Cer. Var.
C5309C A,B,C,D	281-027	7-3 $\mu\text{mf}$	Tub. Var.
C5310A A,B,C,D	281-572	6.8 $\mu\text{mf}$	Cer. 500 v
C5310B A,B,C,D	281-061	5.5-18 $\mu\text{mf}$	Cer. Var.
C5310C A,B,C,D	281-027	7-3 $\mu\text{mf}$	Tub. Var.
C5310E A,B,C,D	281-572	Selected Nominal Value	6.8 $\mu\text{mf}$
C5313A A,B,C,D	281-503	8 $\mu\text{mf}$	Cer. 500 v
C5313B A,B,C,D	281-061	5.5-18 $\mu\text{mf}$	Cer. Var.
C5313C A,B,C,D	281-027	7-3 $\mu\text{mf}$	Tub. Var.
C5313E A,B,C,D	283-539	250 $\mu\text{mf}$	Mica 500 v
C5317 A,B,C,D	281-060	2-8 $\mu\text{mf}$	Cer. Var.
C5318 A,B,C,D	283-002	.01 $\mu\text{f}$	Discap 500 v
C5322 A,B,C,D	283-005	.01 $\mu\text{f}$	Discap 250 v
C5325 A,B,C,D	281-0542-00	18 $\mu\text{mf}$	Cer. 500 v
C5325 A	281-0063-00	9-35 $\mu\text{mf}$	Cer. Var.
C5325 B,C,D	281-0542-00	18 $\mu\text{mf}$	Cer. 500 v
C5327 A,B,C,D	281-523	100 $\mu\text{mf}$	Cer. 350 v
C5327 A,B,C,D	281-0543-00	270 $\mu\text{mf}$	Cer. 500 v
C5327 A	281-0605-00	200 $\mu\text{mf}$	Cer. 500 v
C5327A	281-0638-00	240 $\mu\text{mf}$	Cer. 500 v
C5327 B,C,D	281-0543-00	270 $\mu\text{mf}$	Cer. 500 v
C5333 A,B,C,D	281-580	470 $\mu\text{mf}$	Cer. 500 v
C5348	283-028	.0022 $\mu\text{f}$	Discap 50 v
C5355	281-0580-00	470 $\mu\text{mf}$	Cer. 500 v
C5357	281-580	470 $\mu\text{mf}$	Cer. 500 v
C5375	283-0027-00	.02 $\mu\text{f}$	Discap 30 v
C5378	281-0580-00	470 $\mu\text{mf}$	Cer. 500 v
C5378	281-0551-00	390 $\mu\text{mf}$	Cer. 500 v
C5380	283-0000-00	.001 $\mu\text{f}$	Discap 500 v
C5388	283-0000-00	.001 $\mu\text{f}$	Discap 500 v

**Capacitors (Cont'd)**

Ckt. No.	Tektronix Part Number		Description			S/N Range
C5390	283-026	.2 $\mu$ f	Discap	25 v		
C5391	283-010	.05 $\mu$ f	Discap	50 v		
C5392	Use 283-057	.1 $\mu$ f	Discap	200 v		
C5394	283-004	.02 $\mu$ f	Hi-Kap	150 v		
C5395	Use 283-057	.1 $\mu$ f	Discap	200 v		
C5396	283-0002-00	.01 $\mu$ f	Discap	500 v		X6340-up
C5397	283-0002-00	.01 $\mu$ f	Discap	500 v		X6340-up
C6317	281-540	51 $\mu$ $\mu$ f	Cer.	500 v	5%	
C6318	283-003	.01 $\mu$ f	Hi-Kap	150 v		
C6327	281-540	51 $\mu$ $\mu$ f	Cer.	500 v	5%	
C6337	281-540	51 $\mu$ $\mu$ f	Cer.	500 v	5%	
C6347	281-540	51 $\mu$ $\mu$ f	Cer.	500 v	5%	
C6350	281-518	47 $\mu$ $\mu$ f	Cer.	500 v		101-824
C6350	281-580	470 $\mu$ $\mu$ f	Cer.	500 v	3.3%	825-up
C6351	281-524	150 $\mu$ $\mu$ f	Cer.	500 v		101-824X
C6352	281-524	150 $\mu$ $\mu$ f	Cer.	500 v		101-824
C6352	281-523	100 $\mu$ $\mu$ f	Cer.	350 v		825-3479
C6352	281-607	120 $\mu$ $\mu$ f	Cer.	500 v	5%	3480-up
C6353	281-543	270 $\mu$ $\mu$ f	Cer.	500 v	10%	101-824X
C6354	283-026	.2 $\mu$ f	Discap	25 v		101-649
C6354	283-003	.01 $\mu$ f	Discap	150 v		650-824X
C6355	281-515	27 $\mu$ $\mu$ f	Cer.	500 v	$\pm 1.35 \mu$ $\mu$ f	X825-3479
C6355	281-577	14 $\mu$ $\mu$ f	Cer.	500 v	5%	3480-up
C6356	281-504	10 $\mu$ $\mu$ f	Cer.	500 v	10%	X3480-up
C6364	281-536	1000 $\mu$ $\mu$ f	Cer.	500 v	10%	

**Diodes**

D5324 A,B,C,D	152-008	T12G	Germanium			101-9499
D5324A,B,C,D	*152-0185-00	Silicon	Replaceable by	1N4152		9500-up
D5325 A,B,C,D	152-0008-00	T12G	Germanium			X5970-9499
D5325A,B,C,D	*152-0185-00	Silicon	Replaceable by	1N4152		9500-up
D5345 A,B,C,D	152-079	HD1841	Germanium			101-7799
D5345A,B,C,D	*152-0185-00	Silicon	Replaceable by	1N4152		7800-up
D5346 A,B,C,D	152-079	HD1841	Germanium			101-7799
D5346A,B,C,D	*152-0185-00	Silicon	Replaceable by	1N4152		7800-up
D5347 A,B,C,D	152-079	HD1841	Germanium			101-7799
D5347A,B,C,D	*152-0185-00	Silicon	Replaceable by	1N4152		7800-up
D5348 A,B,C,D	152-079	HD1841	Germanium			101-7799
D5348A,B,C,D	*152-0185-00	Silicon	Replaceable by	1N4152		7800-up
D5360	152-008	T12G	Germanium			101-9499
D5360	*152-0185-00	Silicon	Replaceable by	1N4152		9500-up
D5370	152-008	T12G	Germanium			101-9499
D5370	*152-0185-00	Silicon	Replaceable by	1N4152		9500-up
D5390	152-059	12.6 v	Zener			101-3479X
D5391	Use 152-0034-00	1N753	Zener 0.4 w, 6.2 v, 10%			
D5392	} 152-137	13.6 v	Zener (1 pair)			X3480-up
D5393						

**Diodes (Cont'd)**

Ckt. No.	Tektronix Part Number		Description	S/N Range
D6352	Use *152-0075-00	Tek Spec	Germanium	101-824
D6352	152-075	6075	Germanium	825-9499
D6352	*152-0185-00	Silicon	Replaceable by 1N4152	9500-up
D6355	152-008	T12G	Germanium	X825-9499
D6355	*152-0185-00	Silicon	Replaceable by 1N4152	9500-up
D6356	*152-0185-00	Silicon	Replaceable by 1N4152	X9500-up
D6360	152-008	T12G	Germanium	101-9499
D6360	*152-0185-00	Silicon	Replaceable by 1N4152	9500-up
D6362	152-075	6075	Germanium	X825-9499
D6362	*152-0185-00	Silicon	Replaceable by 1N4152	9500-up
D6363	*152-0185-00	Silicon	Replaceable by 1N4152	X9500-up
D6364	152-008	T12G	Germanium	101-824X
D6368	152-008	T12G	Germanium	101-824X

**Inductors**

L5360	*108-056	1.2 $\mu$ h			101-6339
L5360	*108-0072-00	.75 $\mu$ h			6340-up
L5363	*114-053	3.3-6 $\mu$ h	Var.	Core 276-506	
L5370	*108-056	1.2 $\mu$ h			101-6339
L5370	*108-0072-00	.75 $\mu$ h			6340-up
L5373	*114-053	3.3-6 $\mu$ h	Var.	Core 276-506	
L5384	*108-112	.3 $\mu$ h, 10 turns #30 wire on $\frac{1}{2}$ w, 15 $\Omega$ res.			101-6339X
L5386	*108-112	.3 $\mu$ h, 10 turns #30 wire on $\frac{1}{2}$ w, 15 $\Omega$ res.			101-6339X

**Resistors**

Resistors are fixed, composition,  $\pm 10\%$  unless otherwise indicated.

R5308C A,B,C,D	309-381	600 k	$\frac{1}{2}$ w	Prec.	1%	
R5308E A,B,C,D	309-382	666.6 k	$\frac{1}{2}$ w	Prec.	1%	
R5309C A,B,C,D	309-288	800 k	$\frac{1}{2}$ w	Prec.	1%	
R5309E A,B,C,D	309-162	250 k	$\frac{1}{2}$ w	Prec.	1%	
R5310C A,B,C,D	309-142	900 k	$\frac{1}{2}$ w	Prec.	1%	
R5310E A,B,C,D	309-138	111 k	$\frac{1}{2}$ w	Prec.	1%	
R5313C A,B,C,D	309-145	990 k	$\frac{1}{2}$ w	Prec.	1%	
R5313E A,B,C,D	309-135	10.1 k	$\frac{1}{2}$ w	Prec.	1%	
R5316 A,B,C,D	317-200	20 $\Omega$	.1 w		5%	
R5317 A,B,C,D	309-148	1 meg.	$\frac{1}{2}$ w	Prec.	1%	
R5318 A,B,C,D	302-105	1 meg.	$\frac{1}{2}$ w			
R5319 A,B,C,D	316-470	47 $\Omega$	$\frac{1}{4}$ w			
R5322 A,B,C,D	316-470	47 $\Omega$	$\frac{1}{4}$ w			
R5323 A,B,C,D	304-683	68 k	1 w			
R5324 A,B,C,D	309-211	150 $\Omega$	$\frac{1}{2}$ w	Prec.	1%	
R5325 A,B,C,D	302-333	33 k	$\frac{1}{2}$ w			
R5326 A,B,C,D Use	*311-297	215 $\Omega$		Var.	WW	VAR. GAIN
R5327 A,B,C,D	318-066	50 $\Omega$	$\frac{1}{8}$ w	Prec.	1%	101-6339
R5327 A,B,C,D	321-0039-00	24.9 $\Omega$	$\frac{1}{8}$ w	Prec.	1%	6340-up
R5331 A,B,C,D	302-391	390 $\Omega$	$\frac{1}{2}$ w			

Resistor (Cont'd)

Ckt. No.	Tektronix Part Number		Description			S/N Range
R5332 A,B,C,D	311-258	100 Ω	1/2 w	Var.	DC BAL.	
R5333 A,B,C,D	302-101	100 Ω	1/2 w			101-2759
R5333 A,B,C,D	302-680	68 Ω	1/2 w			2760-5789
R5333 A,B,C,D	302-0470-00	47 Ω	1/2 w			5790-up
R5334 A,B,C,D	309-211	150 Ω	1/2 w		Prec. 1%	
R5335 A,B,C,D	302-333	33 k	1/2 w			
R5336 A,B,C,D	311-258	100 Ω	1/2 w	Var.	GAIN ADJ.	
R5340 A,B,C,D	303-303	30 k	1 w		5%	
R5341 A,B,C,D	316-472	4.7 k	1/4 w			
R5342 A,B,C,D	311-170	20 k		Var.	POSITION	
R5343 A,B,C,D	316-472	4.7 k	1/4 w			
R5344 A,B,C,D	315-0272-00	2.7 k	1/4 w		5%	X6340-up
R5345 A,B,C,D	302-152	1.5 k	1/2 w			101-649
R5345 A,B,C,D	318-043	1.62 k	1/8 w		Prec. 1%	650-up
R5347 A,B,C,D	302-152	1.5 k	1/2 w			101-649
R5347 A,B,C,D	318-043	1.62 k	1/8 w		Prec. 1%	650-up
R5348	301-510	51 Ω	1/2 w		5%	X2760-up
R5349	301-104	100 k	1/2 w		5%	X2760-up
R5350	302-152	1.5 k	1/2 w			101-2759
R5350	315-152	1.5 k	1/4 w		5%	2760-up
R5351	301-152	1.5 k	1/2 w		5%	
R5352	301-131	130 Ω	1/2 w		5%	101-2759X
R5353	315-563	56 k	1/4 w		5%	X2760-up
R5354	311-066	500 Ω	.2 w	Var.	Output DS Level	101-2759
R5354	311-153	10 k		Var.		2760-up
R5355	301-751	750 Ω	1/2 w		5%	101-2759
R5355	301-103	10 k	1/2 w		5%	2760-up
R5356	315-152	1.5 k	1/4 w		5%	X2760-up
R5357	301-151	150 Ω	1/2 w		5%	
R5358	301-302	3 k	1/2 w		5%	
R5359	303-303	30 k	1 w		5%	
R5360	302-154	150 k	1/2 w			
R5361	316-470	47 Ω	1/4 w			
R5362	316-470	47 Ω	1/4 w			
R5363	309-083	700 Ω	1/2 w		Prec. 1%	X650-up 101-6339
R5363	309-0097-00	600 Ω	1/2 w		Prec. 1%	6340-up
R5365	308-211	12 k	5 w		WW	101-6339
R5365	308-0054-00	10 k	5 w		WW 5%	6340-up
R5370	302-154	150 k	1/2 w			
R5371	316-470	47 Ω	1/4 w			
R5372	316-470	47 Ω	1/4 w			X650-up
R5373	309-083	700 Ω	1/2 w		Prec. 1%	101-6339
R5373	309-0097-00	600 Ω	1/2 w		Prec. 1%	6340-up
R5375	301-0621-00	620 Ω	1/2 w		5%	X6340-up
R5377	302-390	39 Ω	1/2 w			101-9059
R5377	302-0560-00	56 Ω	1/2 w			9060-up
R5378	311-258	100 Ω	1/2 w	Var.	Vert. Pos. Range	
R5380	304-0392-00	3.9 k	1 w			X6340-up
R5381	316-470	47 Ω	1/4 w			
R5382	316-470	47 Ω	1/4 w			101-6339



Resistor (Cont'd)

Ckt. No.	Tektronix Part Number		Description			S/N Range
R5382	303-0822-00	8.2 k	1 w		5%	6340-up
R5384	303-912	9.1 k	1 w		5%	
R5385	311-008	2 k	2 w	Var.	HF Peaking	
R5386	303-912	9.1 k	1 w		5%	
R5388	316-470	47 Ω	1/4 w			
R5389	316-470	47 Ω	1/4 w			101-6339
R5389	303-0822-00	8.2 k	1 w		5%	6340-up
R5390	308-127	2.5 k	5 w		WW	X825-5789
R5390	308-0091-00	2 k	5 w		WW	5790-up
R5391	302-121	120 Ω	1/2 w			
R5392	304-562	5.6 k	1 w			
R5393	301-0180-00	18 Ω	1/2 w		5%	X5790-up
R5394	304-332	3.3 k	1 w			
R6310	315-103	10 k	1/4 w		5%	101-3479
R6310	315-752	7.5 k	1/4 w		5%	3480-up
R6311	316-101	100 Ω	1/4 w			X4791-up
R6312	318-018	2.94 k	1/8 w		Prec.	1%
R6313	318-009	10.1 k	1/8 w		Prec.	1%
R6314	318-009	10.1 k	1/8 w		Prec.	1%
R6315	318-009	10.1 k	1/8 w		Prec.	1%
R6316	301-681	680 Ω	1/2 w		5%	
R6317	301-202	2 k	1/2 w		5%	
R6318	308-212	10 k	3 w		WW	
R6319	316-470	47 Ω	1/4 w			
R6320	315-103	10 k	1/4 w		5%	101-3479
R6320	315-752	7.5 k	1/4 w		5%	3480-up
R6321	316-101	100 Ω	1/4 w			X4791-up
R6322	318-018	2.94 k	1/8 w		Prec.	1%
R6323	318-009	10.1 k	1/8 w		Prec.	1%
R6324	318-009	10.1 k	1/8 w		Prec.	1%
R6325	318-009	10.1 k	1/8 w		Prec.	1%
R6327	301-202	2 k	1/2 w		5%	
R6329	316-470	47 Ω	1/4 w			
R6330	315-103	10 k	1/4 w		5%	101-3479
R6330	315-752	7.5 k	1/4 w		5%	3480-up
R6331	316-101	100 Ω	1/4 w			X4791-up
R6332	318-018	2.94 k	1/8 w		Prec.	1%
R6333	318-009	10.1 k	1/8 w		Prec.	1%
R6334	318-009	10.1 k	1/8 w		Prec.	1%
R6335	318-009	10.1 k	1/8 w		Prec.	1%
R6337	301-202	2 k	1/2 w		5%	
R6339	316-470	47 Ω	1/4 w			
R6340	315-103	10 k	1/4 w		5%	101-3479
R6340	315-752	7.5 k	1/4 w		5%	3480-up
R6341	316-101	100 Ω	1/4 w			X4791-up

**Resistors (Cont'd)**

Ckt. No.	Tektronix Part No.		Description			S/N Range
R6342	318-018	2.94 k	1/8 w	Prec.	1%	
R6343	318-009	10.1 k	1/8 w	Prec.	1%	
R6344	318-009	10.1 k	1/8 w	Prec.	1%	
R6345	318-009	10.1 k	1/8 w	Prec.	1%	
R6347	301-202	2 k	1/2 w		5%	
R6350	301-242	2.4 k	1/2 w		5%	X825-up
R6351	301-102	1 k	1/2 w		5%	
R6353	301-102	1 k	1/2 w		5%	101-824
R6353	301-273	27 k	1/2 w		5%	825-3479
R6353	301-153	15 k	1/2 w		5%	3480-up
R6354	301-162	1.6 k	1/2 w		5%	101-824X
R6355	301-223	22 k	1/2 w		5%	101-824X
R6356	301-474	470 k	1/2 w		5%	101-649
R6356	301-334	330 k	1/2 w		5%	650-824
R6356	301-224	220 k	1/2 w		5%	825-3479
R6356	309-279	180 k	1/2 w	Prec.	1%	3480-9499
R6356	322-0402-00	150 k	1/4 w	Prec.	1%	9500-up
R6359	315-0333-00	33 k	1/4 w		5%	X9500-up
R6360	301-184	180 k	1/2 w		5%	101-824
R6360	309-051	200 k	1/2 w	Prec.	1%	825-3479
R6360	309-234	154 k	1/2 w	Prec.	1%	3480-up
R6361	301-102	1 k	1/2 w		5%	101-649
R6361	301-331	330 Ω	1/2 w		5%	650-824
R6361	301-102	1 k	1/2 w		5%	825-up
R6362	301-153	15 k	1/2 w		5%	X825-up
R6363	301-474	470 k	1/2 w		5%	101-824X
R6364	301-751	750 Ω	1/2 w		5%	101-824
R6364	301-822	8.2 k	1/2 w		5%	825-up
R6365	301-223	22 k	1/2 w		5%	101-824
R6365	309-107	26.67 k	1/2 w	Prec.	1%	825-up
R6366	301-104	100 k	1/2 w		5%	101-824
R6366	309-260	100 k	1/2 w	Prec.	1%	825-up
R6367	301-103	10 k	1/2 w		5%	101-824X
R6368	301-751	750 Ω	1/2 w		5%	101-824X

**Transformer**

T6350      \*120-193      Toroid TD #26

**Transistors**

Q5324 A,B,C,D	151-067	2N1143				101-9499
Q5324A,B,C,D	151-0221-00	2N4258				9500-up
Q5334 A,B,C,D	151-067	2N1143				101-9499
Q5334A,B,C,D	151-0221-00	2N4258				9500-up
Q5344	151-062	N101				101-2759
Q5344A,B	*151-104	SP8481 (or Equivalent)				2706-9499
Q5344A,B	151-0249-00	Dual				9500-up
Q5354	151-063	PADT35				101-9499
Q5354	151-0220-00	2N4122				9500-up
Q6315	151-076	2N2048				101-9499

**Transistors (Cont'd)**

Ckt. No.	Tektronix Part No.	Description	S/N Range
Q6315	*151-0219-00	2N4250 (or Equivalent)	9500-up
Q6325	151-076	2N2048	101-9499
Q6325	*151-0219-00	2N4250 (or Equivalent)	9500-up
Q6335	151-076	2N2048	101-9499
Q6335	*151-0219-00	2N4250 (or Equivalent)	9500-up
Q6345	151-076	2N2048	101-9499
Q6345	*151-0219-00	2N4250 (or Equivalent)	9500-up
Q6350	151-076	2N2048	101-9499
Q6350	151-0220-00	2N4122	9500-up
Q6364	151-076	2N2048	101-824
Q6364	151-062	N101	825-9499
Q6364	151-0224-00	2N3692	9500-up

**Switches**

	Unwired	Wired		
SW5300 A,B,C,D	260-401	*262-434	Rotary	MODE
SW5300 A,B,C,D	260-401	*262-572	Rotary	MODE
SW5300A,B,C,D	260-0401-00	*262-0572-01	Rotary	MODE
SW5310 A,B,C,D	260-402	*262-435	Rotary	VOLTS/CM
SW6367	260-212			Slide, DPDT
SW6367	260-0447-00			Slide, DPDT

**Electron Tubes**

V5323A,B,C,D	Use *157-0121-00	7586, Checked	
V5364 } V5374 }	† Use *157-078	8426	
V5383	154-0039-02	12AT7	101-9059
V5383	*157-0118-00	12AT7, Aged and checked	9060-up

† V5364 & V5374 furnished as a unit.

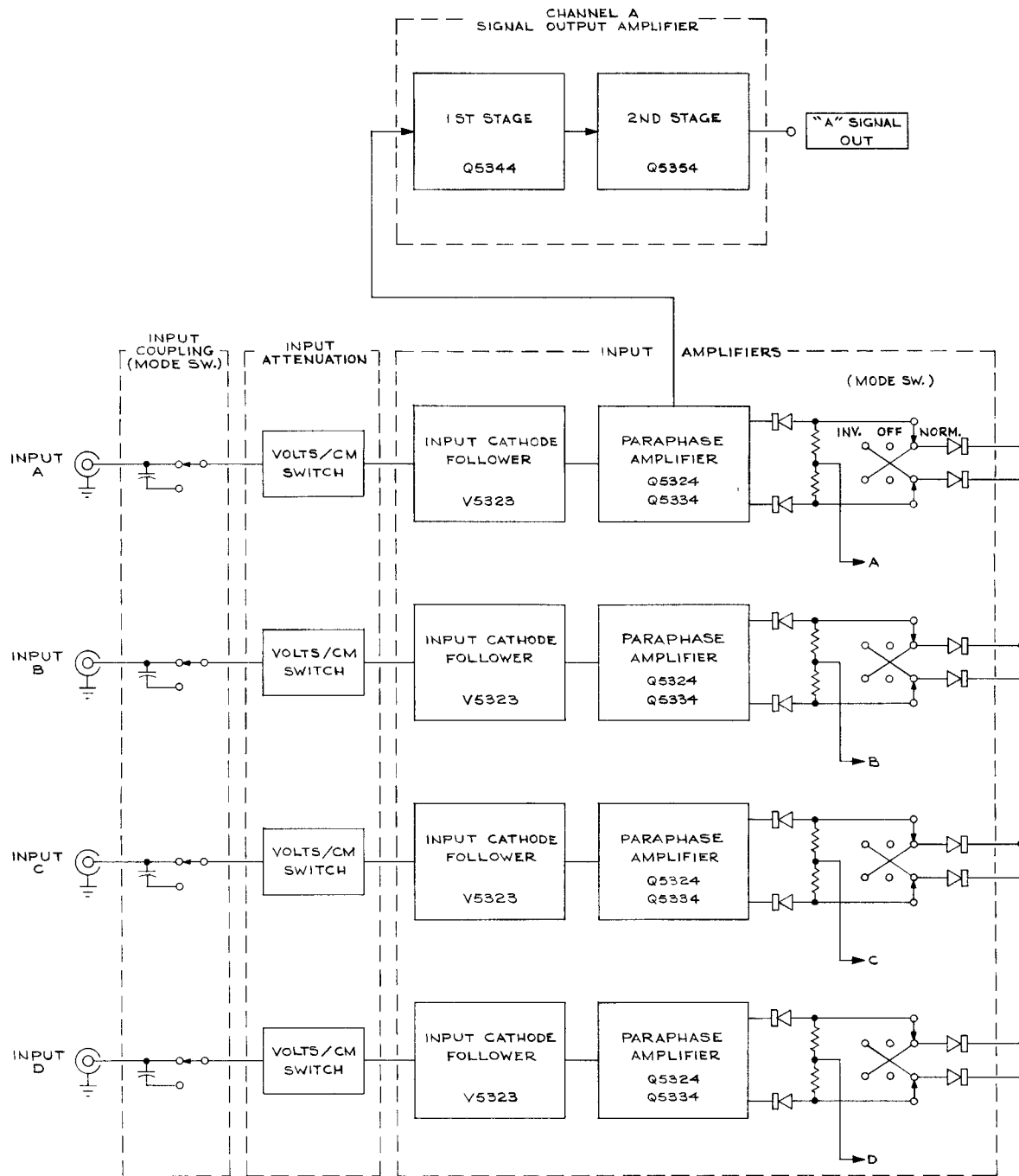

TYPE M PLUG-IN UNIT

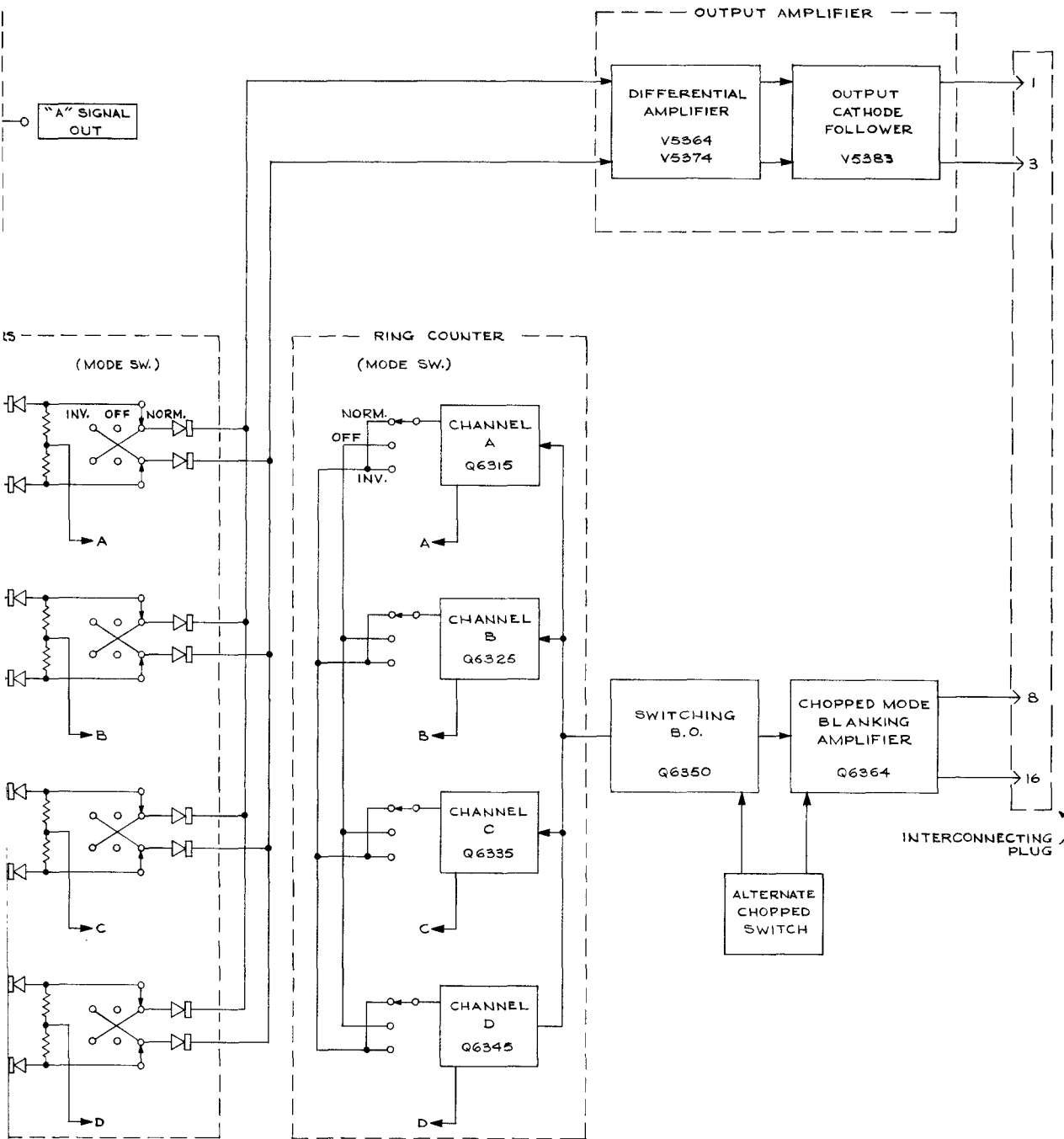

MR4  
1263

BLOCK DIAGRAM

A<sub>1</sub>

TYPICAL SWITCHED ATTENUATOR AND AMPLIFIER (4 REQ'D)

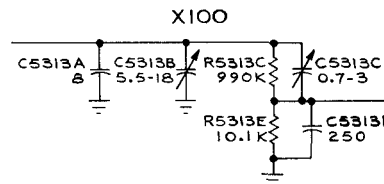
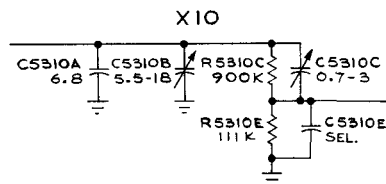
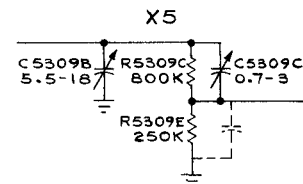
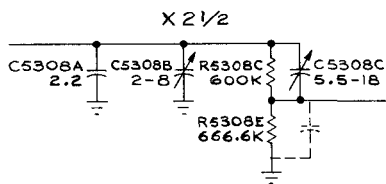
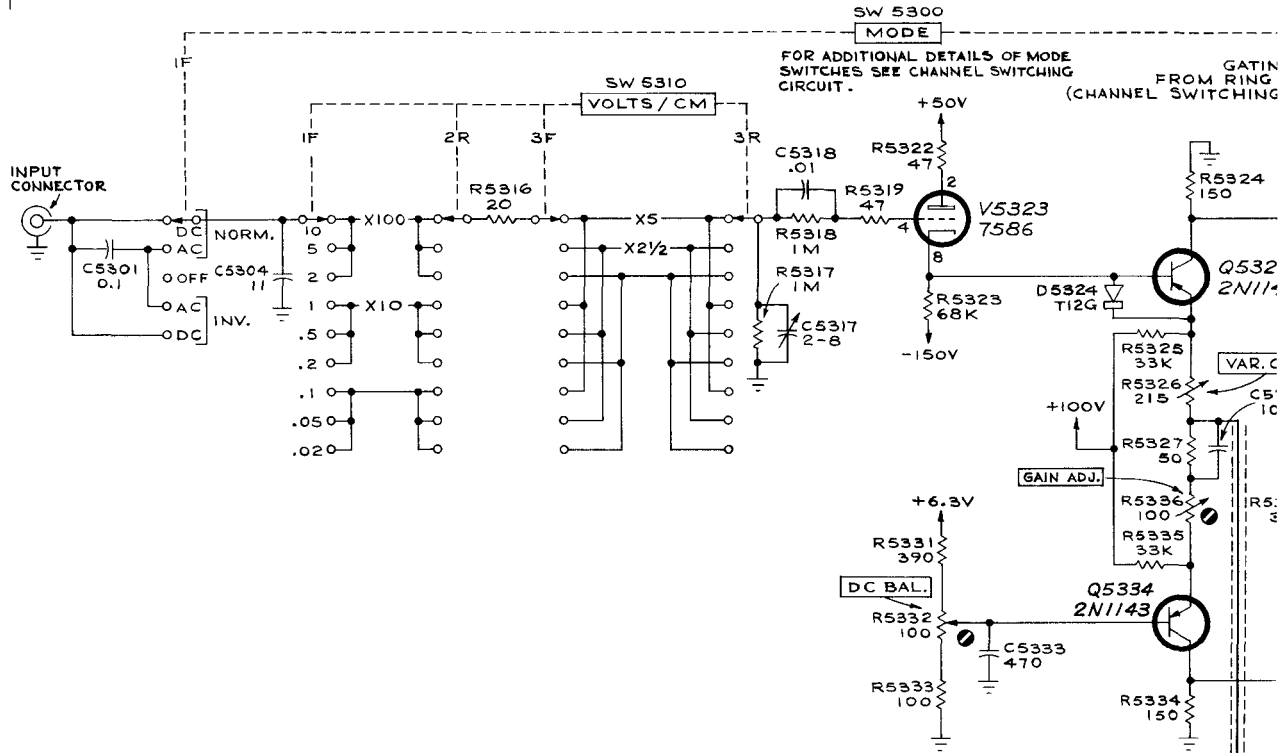

ATTENUATOR DETAILS

SEE PARTS LIST FOR EARLIER VALUES AND S/N CHANGES OF PARTS MARKED WITH BLUE OUTLINE

TYPE M PLUG-IN UNIT

D<sub>2</sub>

+

IFIER (4 REQ'D)

OUTPUT AMPLIFIER

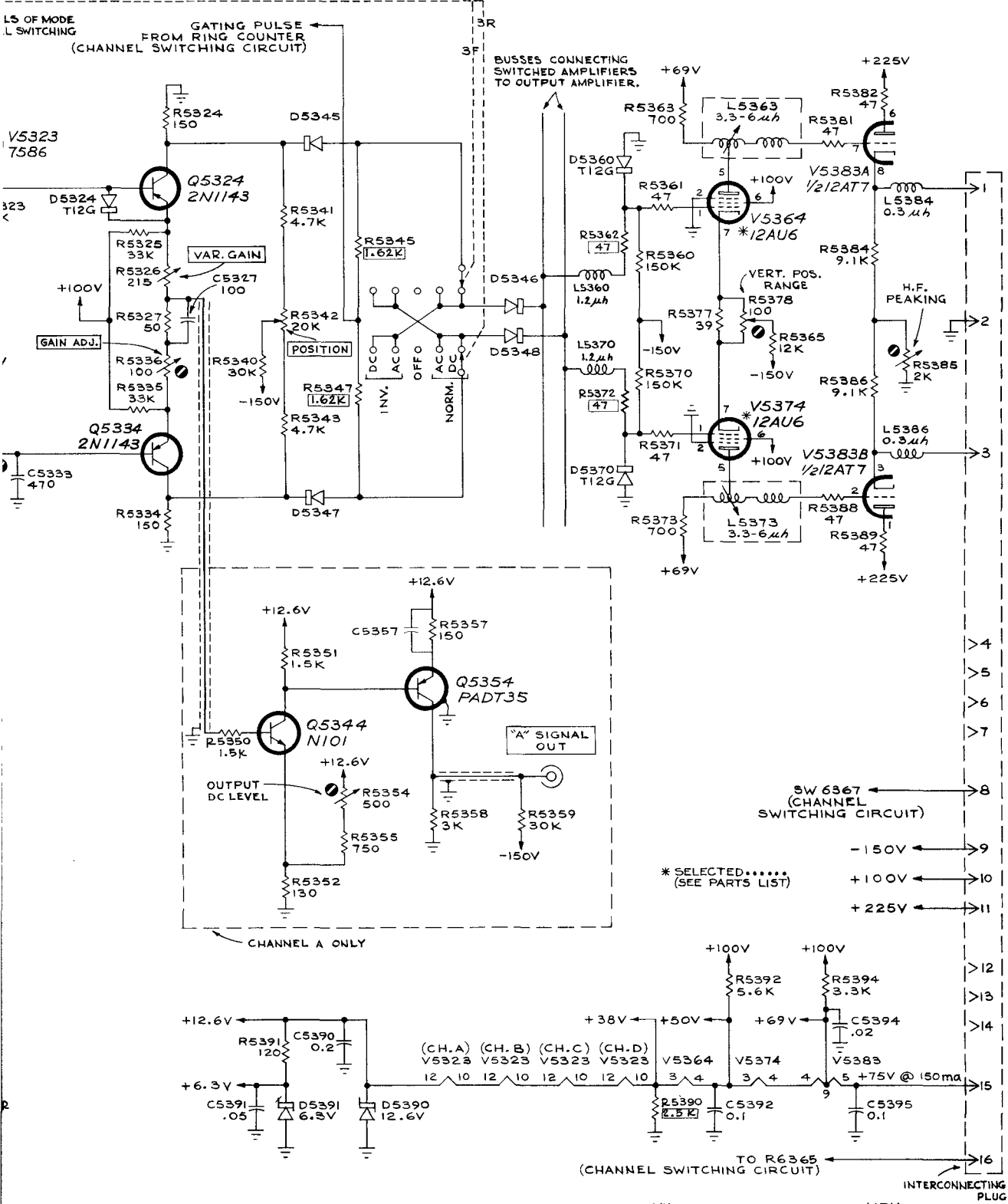

# 4 CHANNEL SWITCHED AMPLIFIER

S/N 101-2759 MRH 03-21-62

D<sub>2</sub>

INTERCONNECTING PLUG

SW 6367 (CHANNEL SWITCHING CIRCUIT)

\* SELECTED..... (SEE PARTS LIST)

CHANNEL A ONLY

TO R6365 (CHANNEL SWITCHING CIRCUIT)

(CH.A)	(CH.B)	(CH.C)	(CH.D)			
V5323	V5323	V5323	V5323	V5364	V5374	V5383
12	10	12	10	3	4	5

+75V @ 150ma

TYPICAL SWITCHED ATTENUATOR AND AMPLIFIER (4 REQ'D)

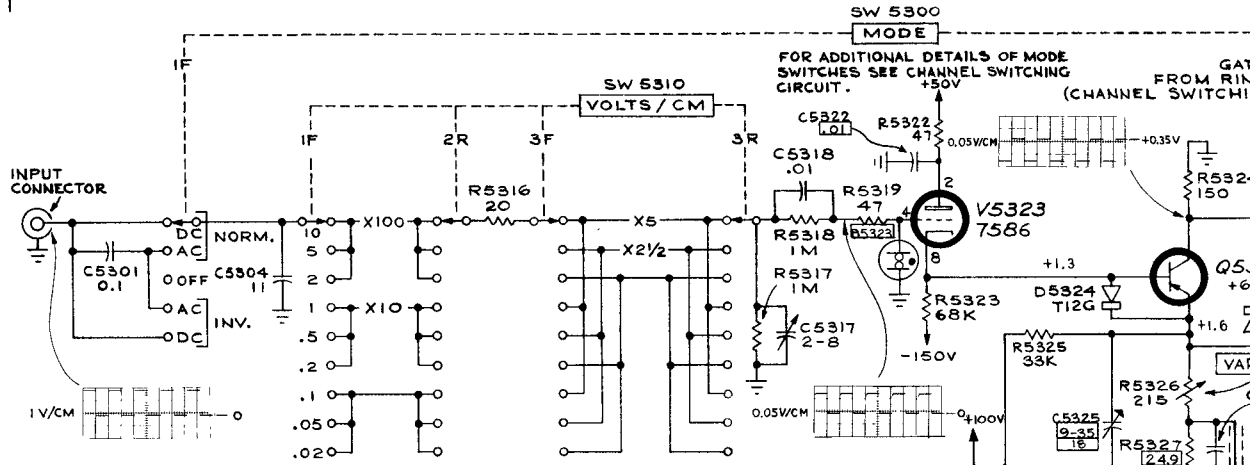

WAVEFORMS and VOLTAGE READINGS obtained under the following conditions:

TEST OSCILLOSCOPE  
 Time/Cm ..... 0.5 msec/cm  
 Volts/Cm ..... See waveforms

M UNIT  
 Voltages:  
 MODE (Channel A) ..... DC NORM  
 MODE (Channels B, C, and D) ..... OFF  
 VAR. GAIN (All channels) ..... CA1B  
 POSITION ..... Midrange  
 ALTERNATE/CHOPPED ..... ALTERNATE

Waveforms:  
 VOLTS/CM ..... 0.5  
 MODE ..... DC NORM  
 VAR. GAIN ..... CA1B  
 POSITION ..... Midrange  
 ALTERNATE/CHOPPED ..... ALTERNATE

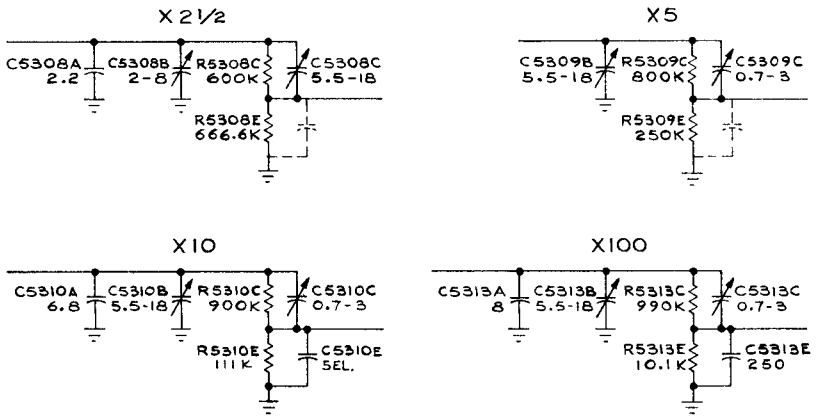
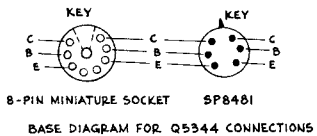
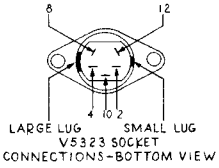

SEE PARTS LIST FOR SEMICONDUCTOR TYPES

SEE PARTS LIST FOR EARLIER VALUES AND S/N CHANGES OF PARTS MARKED WITH BLUE OUTLINE

TYPE M PLUG-IN UNIT

H



AMPLIFIER (4 REQ'D)

OUTPUT AMPLIFIER

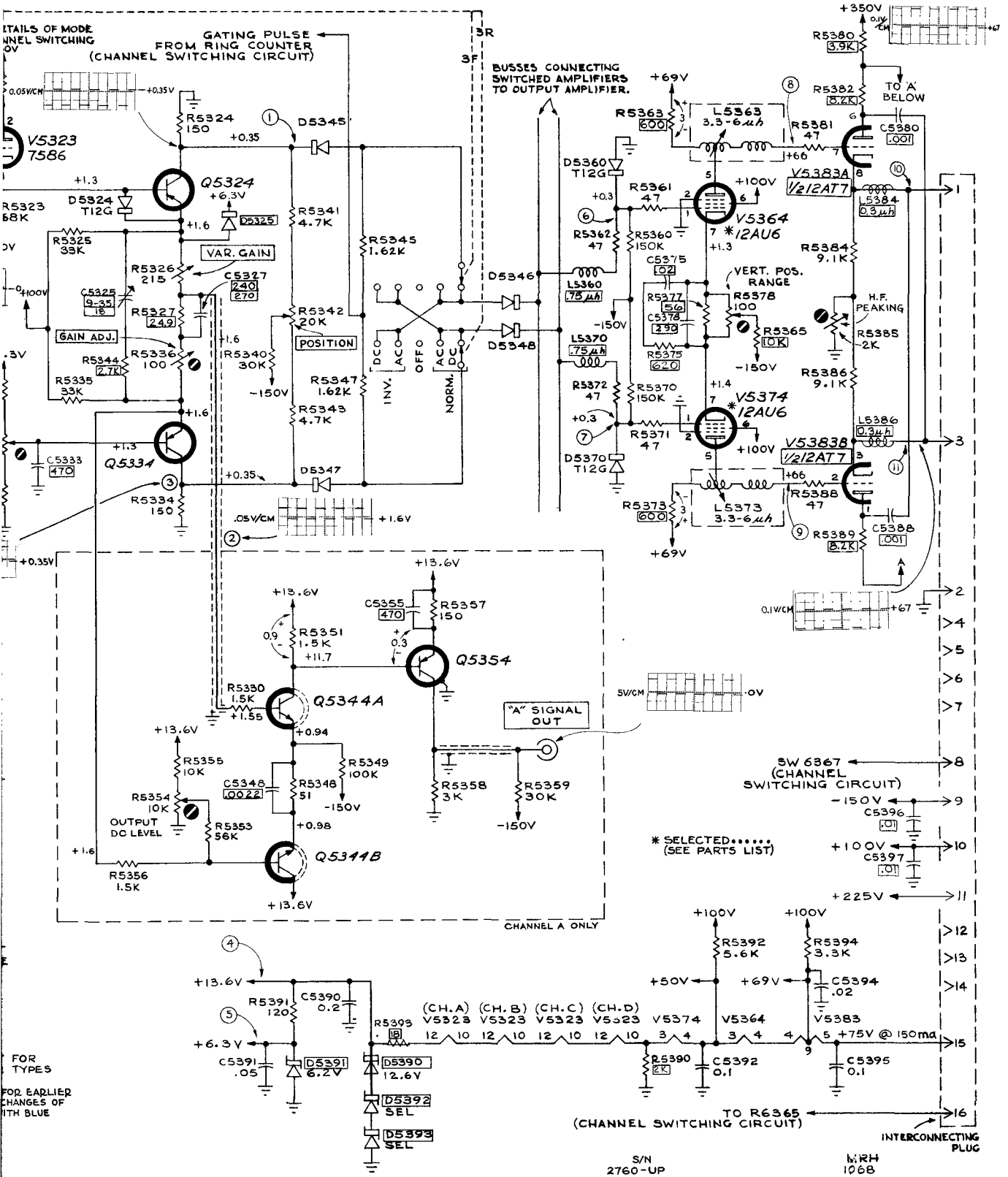

4 CHANNEL SWITCHED AMPLIFIER

FOR EARLIER CHANGES OF WITH BLUE

H

S/N 2760-UP W/RH 1068

RING COUNTER

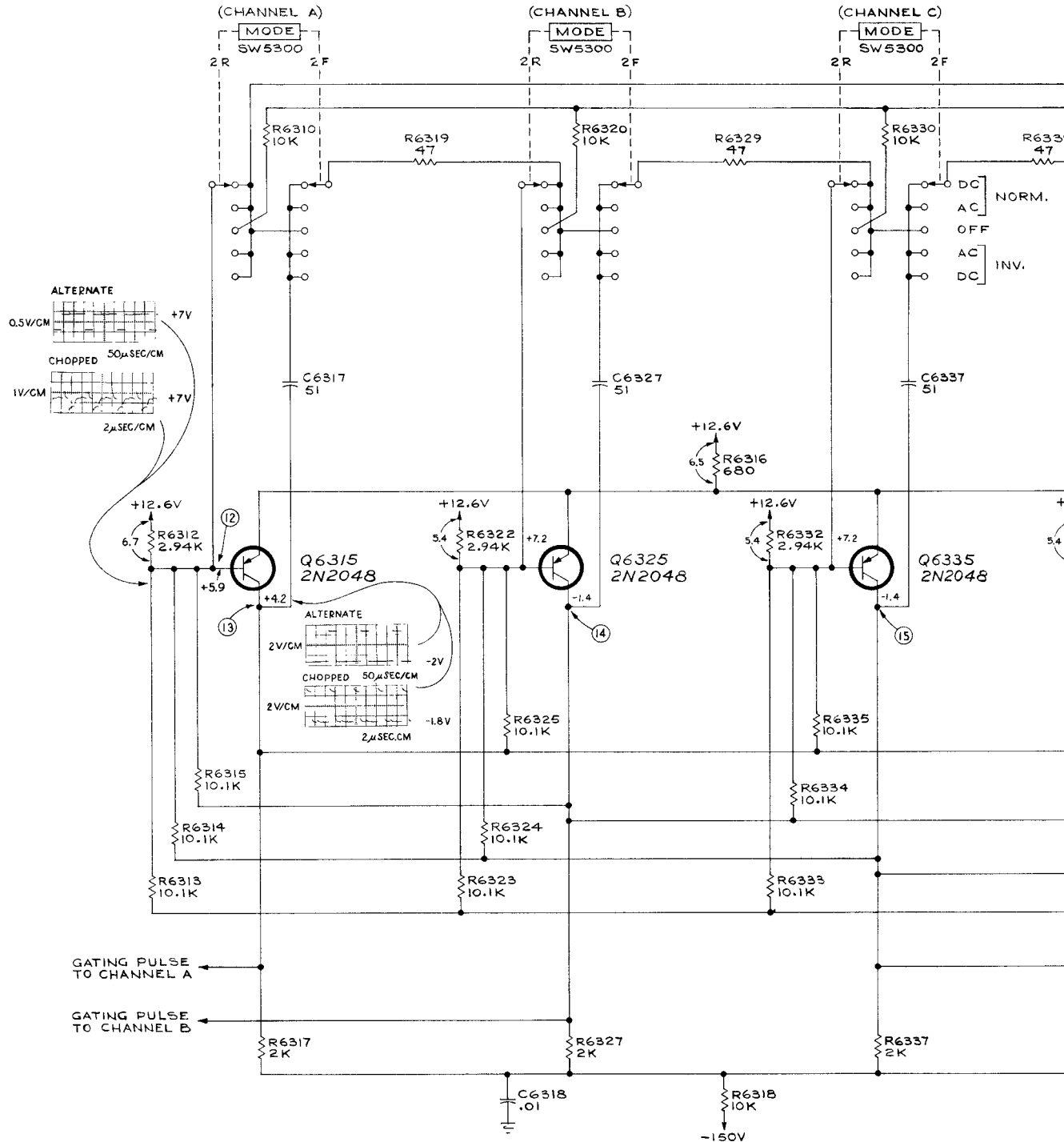

SEE PARTS LIST FOR EARLIER VALUES AND S/N CHANGES OF PARTS MARKED WITH BLUE OUTLINE

TYPE M PLUG-IN UNIT

C<sub>3</sub>

+

+  
 SWITCHING B.O. → CHOPPED MODE  
 BLANKING AMPLIFIER →

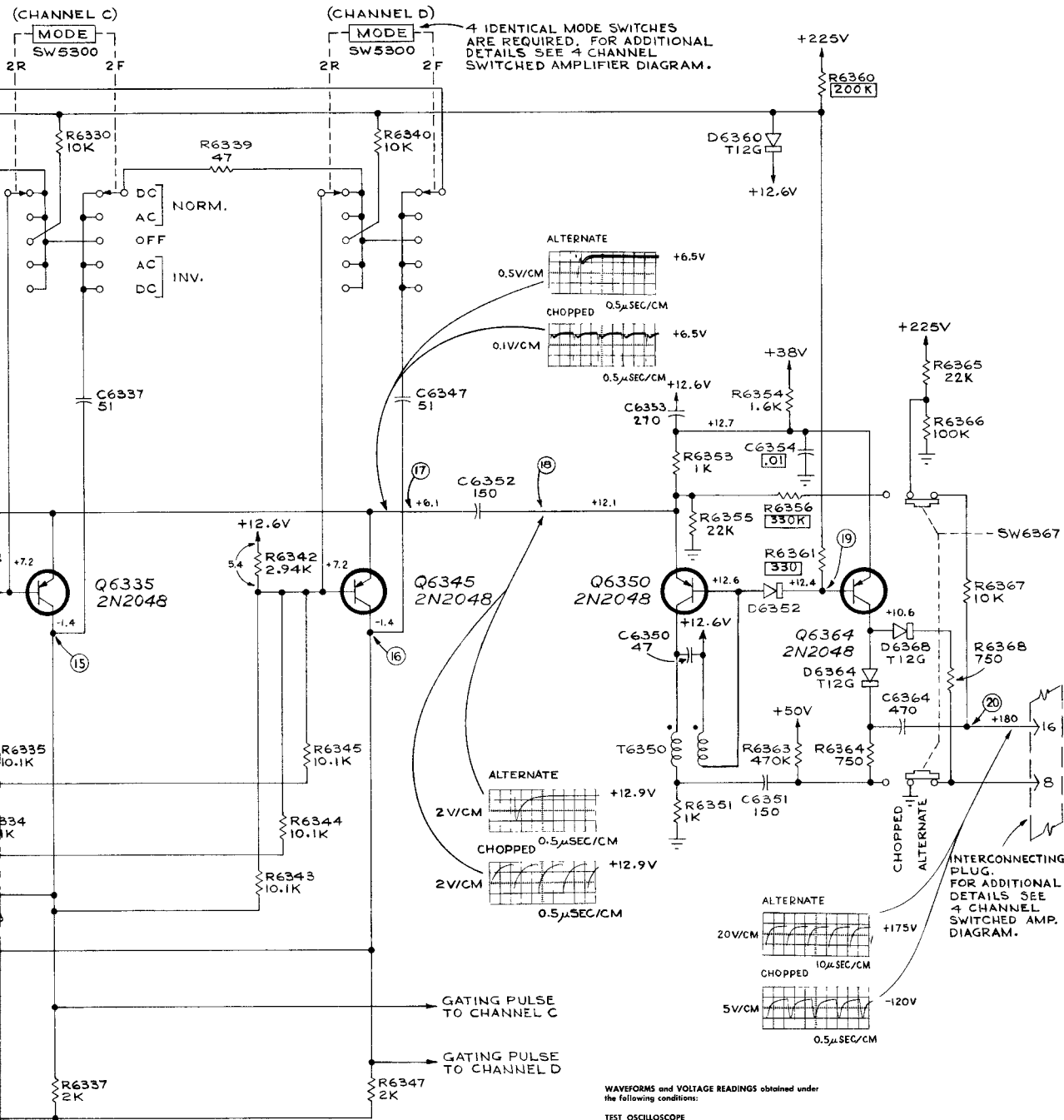

4 IDENTICAL MODE SWITCHES ARE REQUIRED. FOR ADDITIONAL DETAILS SEE 4 CHANNEL SWITCHED AMPLIFIER DIAGRAM.

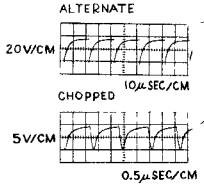
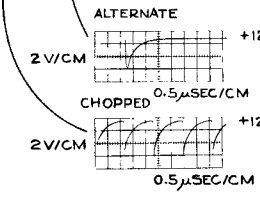
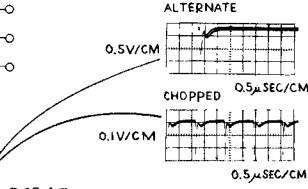

WAVEFORMS and VOLTAGE READINGS obtained under the following conditions:

TEST OSCILLOSCOPE  
 Time/Cm ..... See waveforms  
 Volts/Cm ..... See waveforms

M UNIT

Voltages:

MODE (Channel A) ..... DC NORM  
 MODE (Channels B, C, and D) ..... OFF  
 VAR. GAIN (All channels) ..... CALIB.  
 POSITION (All channels) ..... Midrange  
 ALTERNATE/CHOPPED ..... ALTERNATE  
 (except where noted)

Waveforms:

Some conditions as for the Amplifier circuit diagram except as follows:

1. Signal disconnected from the A input connector.
2. ALTERNATE/CHOPPED switch set to CHOPPED for waveforms so indicated.
3. Oscilloscope used with the M Unit set for 1μsec/cm free-running sweep.

MRH  
 03-21-62

## CHANNEL SWITCHING CIRCUIT

5/N 101-824

RING COUNTER

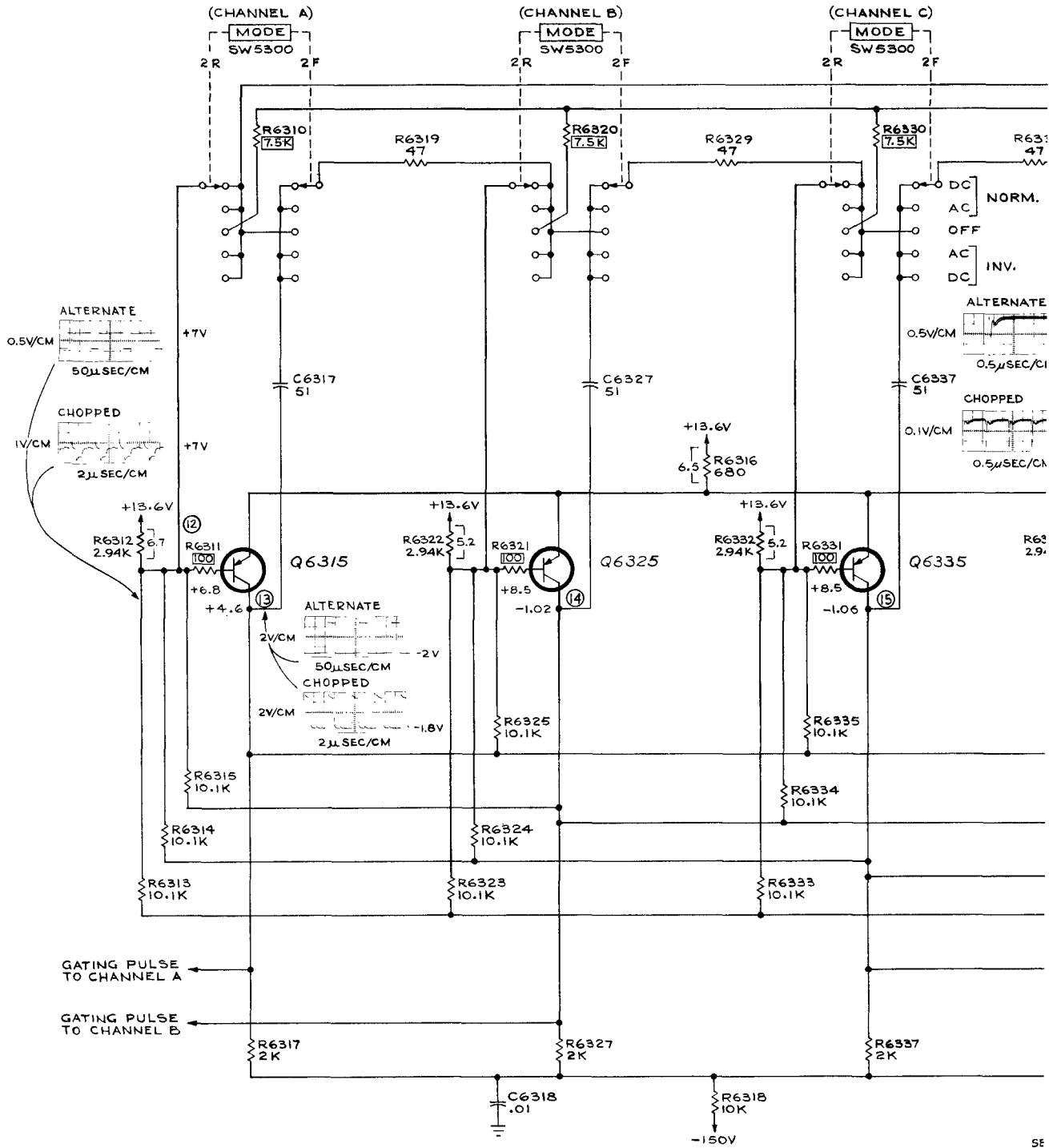

TYPE M PLUG-IN UNIT

+

E

+  
 SWITCHING B.O. CHOPPED MODE  
 BLANKING AMPLIFIER

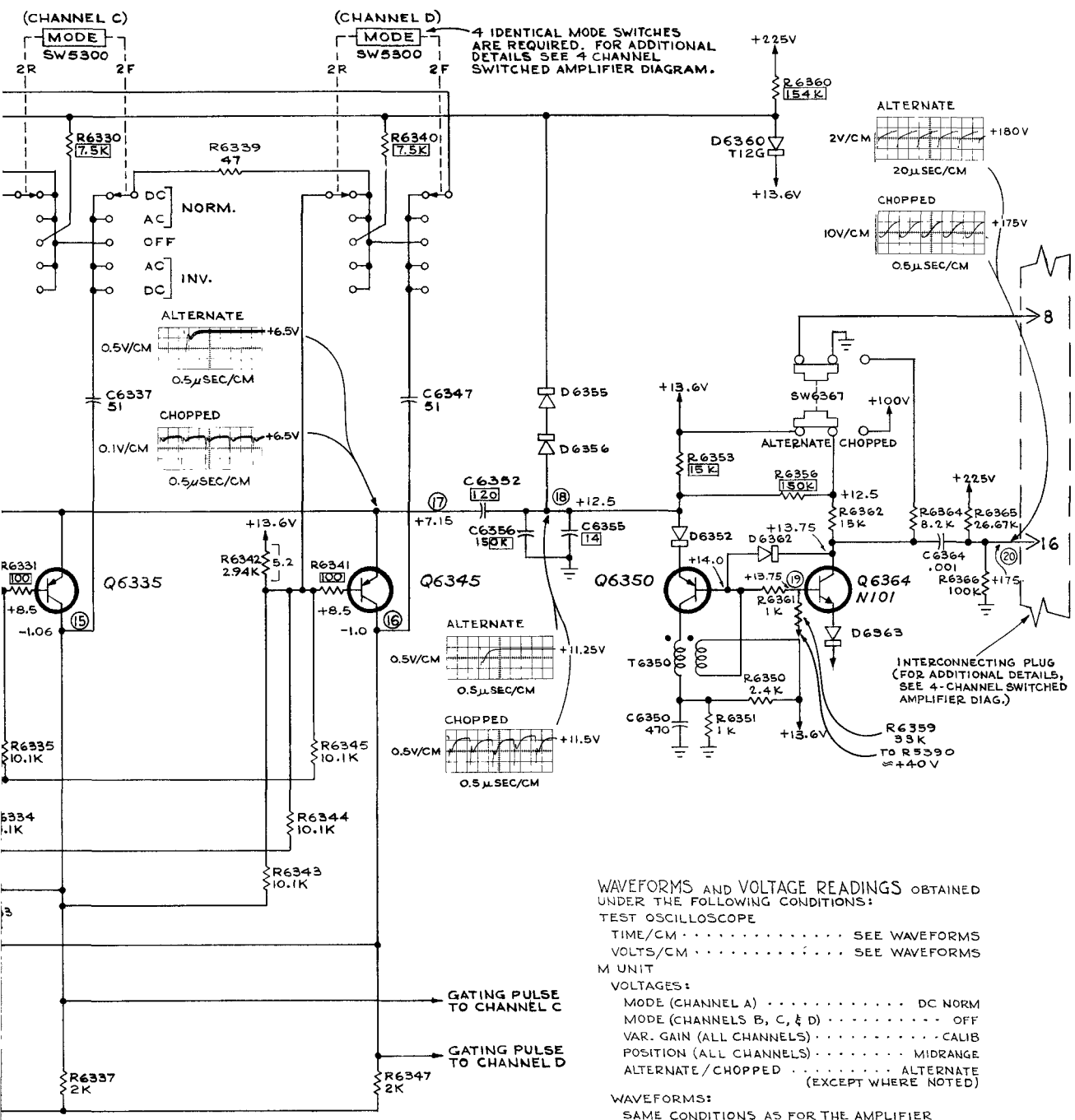

WAVEFORMS AND VOLTAGE READINGS OBTAINED UNDER THE FOLLOWING CONDITIONS:  
 TEST OSCILLOSCOPE  
 TIME/CM . . . . . SEE WAVEFORMS  
 VOLTS/CM . . . . . SEE WAVEFORMS  
 M UNIT  
 VOLTAGES:  
 MODE (CHANNEL A) . . . . . DC NORM  
 MODE (CHANNELS B, C, & D) . . . . . OFF  
 VAR. GAIN (ALL CHANNELS) . . . . . CALIB  
 POSITION (ALL CHANNELS) . . . . . MIDRANGE  
 ALTERNATE/CHOPPED . . . . . ALTERNATE  
 (EXCEPT WHERE NOTED)

WAVEFORMS:  
 SAME CONDITIONS AS FOR THE AMPLIFIER  
 CIRCUIT DIAGRAM EXCEPT AS FOLLOWS:  
 1. SIGNAL DISCONNECTED FROM THE A INPUT  
 CONNECTOR.  
 2. ALTERNATE/CHOPPED SWITCH SET TO CHOPPED  
 FOR WAVEFORMS SO INDICATED.  
 3. OSCILLOSCOPE USED WITH M UNIT SET FOR  
 1 μSEC/CM FREE-RUNNING SWEEP.

SEE PARTS LIST FOR EARLIER  
 VALUES AND S/N CHANGES OF  
 PARTS MARKED WITH BLUE  
 OUTLINE

1068  
 CHANNEL SWITCHING CIRCUIT  
 EFF. 5/N 825-UP

## **MANUAL CHANGE INFORMATION**

At Tektronix, we continually strive to keep up with latest electronic developments by adding circuit and component improvements to our instruments as soon as they are developed and tested.

Sometimes, due to printing and shipping requirements, we can't get these changes immediately into printed manuals. Hence, your manual may contain new change information on following pages.

A single change may affect several sections. Sections of the manual are often printed at different times, so some of the information on the change pages may already be in your manual. Since the change information sheets are carried in the manual until ALL changes are permanently entered, some duplication may occur. If no such change pages appear in this section, your manual is correct as printed.

TYPE M      TENT SN 9340

ELECTRICAL PARTS LIST CORRECTION

CHANGE TO:

D5391	152-0280-00	1N753A	0.4 w, 6.2 V, ±5%
-------	-------------	--------	-------------------

TYPE M

TENT SN 9660

ELECTRICAL PARTS LIST CORRECTION

CHANGE TO:

Q5344A,B

151-0232-00

Silicon

Dual